

GT2297

高速单针曲折缝缝纫机

HIGH-SPEED ONE-NEEDLE ZIGZAG STITCHING MACHINE

Read safety instructions carefully and understand them before using.
Retain this instruction Manual for future reference.

感谢您购买本公司的产品。

为了安全地使用，请您在使用之前一定阅读本使用说明书。

另外，请您注意保管本使用说明书，以便随时查阅。

零件样本目录 CONTENTS

1.	机头、外露部件 (1).....	1
	FRAME & MISCELLANEOUS COVER COMPONENTS(1)	
2.	机座、外露盖板部件 (2).....	5
	FRAME & MISCELLANEOUS COVER COMPONENTS(2)	
3.	机头、外露夹线部件 (3).....	7
	FRAME & MISCELLANEOUS COVER COMPONENTS(3)	
4.	上轴、针杆部件.....	9
	MAIN SHAFT.NEEDLE BAR COMPONENTS	
5.	摆针部件 (1).....	11
	NEEDLE VIBRATOR & ADJUSTMENT COMPONENTS(1)	
6.	摆针部件 (2).....	13
	NEEDLE VIBRATOR & ADJUSTMENT COMPONENTS(2)	
7.	摆针凸轮转换部件 (3).....	15
	NEEDLE VIBRATOR CAM CHANGED COMPONENTS	
8.	压脚部件.....	17
	PRESSER BAR & FEED REGULATOR COMPONENTS	
9.	倒针部件.....	19
	FEED MECHANISM & CONDENSE COMPONENTS	
10.	送料、抬牙部件.....	21
	FEED MECHANISM COMPONENTS	
11.	下轴、勾线部件.....	23
	HOOK DRIVING SHAFT & HOOK COMPONENTS	
12.	润滑部件.....	25
	LUBRICATION COMPONENTS	
13.	线架部件.....	27
	THREAD STAND COMPONENTS	
14.	油盘、膝控部件.....	28
	OIL RESERVOIR & KNEE LIFTER COMPONENTS	
15.	带轮罩部件.....	29
	BELT COVER COMPONENTS	
16.	附件部件 (1).....	30
	ACCESSORIES COMPONENTS	
17.	剪线电磁铁部件.....	31
	THREAD TRIMMER MECHANISM COMPONENTS	
18.	挑线电磁铁部件.....	35
	UPPER THREAD FEEDER COMPONENTS	
19.	倒缝电磁铁部件.....	37
	AUTOMATIC REVERSE FEED MECHANISM COMPONENTS	
20.	扫线电磁铁部件.....	39
	WIPER MECHANISM COMPONENTS	
21.	专用部件.....	41
	APPROPRIATION PARTS	
22.	自动抬压脚装置.....	43
	AUTO LIFTER (ON THE SIDE PLATE)	
23.	附件部件 (2).....	45
	ACCESSORIES COMPONENTS	

1. 机头、外露部件 (1)

FRAME & MISCELLANEOUS COVER COMPONENTS (1)

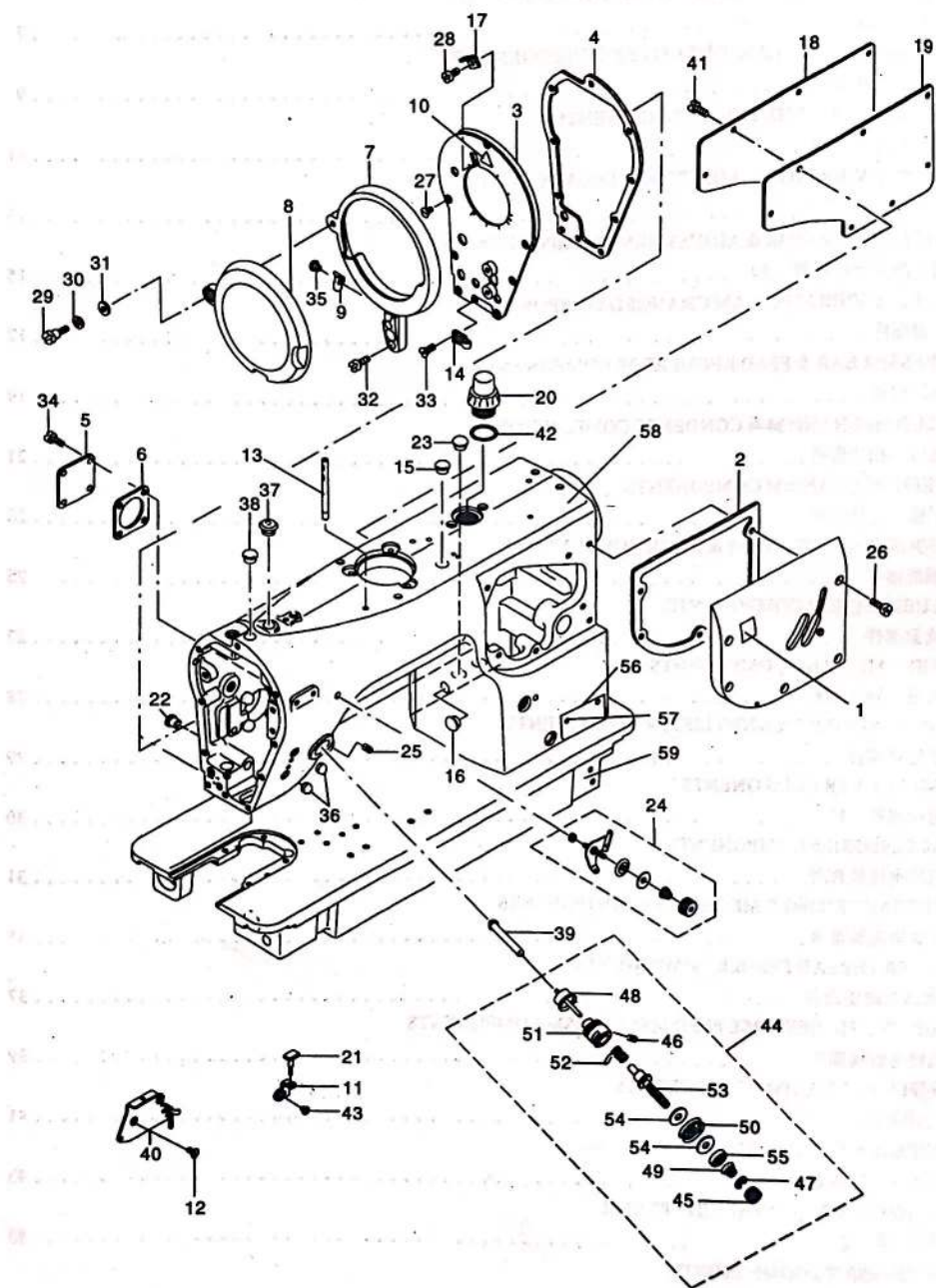

1、FRAME & MISCELLANEOUS COVER COMPONENTS (1)

1、机头、外露部件(1)

序号	图号	名称	DESCRIPTION	2284	2284-7	备注
1	423.01-01	操作图章	OPERATION SEAL	1	1	
2	423.01-02	机壳前盖板垫	GASKET	1	1	
3	423.01-03	面板	FACE PLATE COMPL.	1	1	
4	423.01-04	面板垫	GASKET OF FACE PLATE	1	1	
5	423.01-05	松线窗盖板	TENSION RELEASE WINDOW PLATE	1		
6	423.01-06	松线窗盖板垫	GASKET	1	1	
7	423.01-07	平盖底座	BALANCE COVER BASE	1	1	
8	423.01-08	平盖	BALANCE COVER	1	1	
9	423.01-09	弹簧片	SPRING	1	1	
10	423.01-10	警告标牌	ATTENTION SEAL	1	1	
11	423.01-11	挑线簧防护架	SPRING GUARD	1	1	
12	423.01-12	导线板螺钉	SCREW 11/64-40 L=8	2	2	
13	423.01-13	导线柱	THREAD GUIDE PIN	1	1	
14	423.01-14	面板线勾	SPRING GUARD	1	1	
15	423.01-15	橡皮塞	RUBBER PLUG	1	1	
16	423.01-16	橡皮塞	RUBBER PLUG	1	1	
17	423.01-17	挑线割线刀	TAKE-UP THREAD CUTTER	1	1	
18	423.01-18	后盖板	SIDE PLATE	1		
19	423.01-19	后盖板垫	GASKET	1		
20	423.01-20	示油窗	OIL SIGHT WINDOW	1	1	
21	423.01-21	限位橡皮	RUBBER STOPPER	1	1	
22	423.01-22	橡皮塞	PLUG D=8 L=4.5	1	1	
23	423.01-23	橡皮塞	RUBBER PLUG	1	1	
24	423.01-24	预张力夹线器组件	PRE-TENSION CONTROLLER ASM.	1	1	
25	423.01-25	夹线器螺钉	SCREW 11/64-40 L=6.5	1	1	
26	423.01-26	前盖板螺钉	SCREW 3/16-28 L=14	5	5	
27	423.01-27	面板螺钉	SCREW 11/64-40 L=8	7	7	
28	423.01-28	挑线割线刀螺钉	SCREW 1/8-44 L=3.8	1	1	
29	423.01-29	平盖铰链螺钉	HINGE SCREW D=6.35 H=7.5	1	1	
30	423.01-30	波形垫圈	WAVED WASHER 6.4×11×0.3	1	1	
31	423.01-31	平盖铰链垫圈	WASHER 6.5×11×1	1	1	
32	423.01-32	平盖底座固定螺钉	SCREW 11/64-40 L=9	2	2	
33	423.01-33	面板线勾螺钉	SCREW 9/64-40 L=7	1	1	
34	423.01-34	松线窗盖板螺钉	SCREW 3/16-28 L=6	4	4	
35	423.01-35	弹簧片螺钉	SCREW 3/16-28 L=6	1	1	
36	423.01-36	橡皮塞	DRIVING STOPPER RUBBER	2	2	
37	423.01-37	橡皮塞	RUBBER PLUG	1	1	
38	423.01-38	橡皮塞	PLUG	1	1	
39	423.01-39	松线顶杆	THREAD RELEASE	1	1	
40	423.01-40	导线板	BALANCE THREAD GUIDE	1		
41	423.01-41	后盖板螺钉	SCREW 3/16-28 L=10	8	8	
42	423.01-42	示油窗O形圈	RUBBER RING	1	1	
43	423.01-43	挑线簧防护架螺钉	SCREW 9/64-40 L=3.5	1	2	
44	423.01-44	夹线器组件	THREAD TENSION ASM.	1	1	
45	423.01-44-01	夹线螺母	TENSION NUT	(1)	(1)	
46	423.01-44-02	夹线座螺钉	SCREW 9/64-40 L=5.5	(1)	(1)	
47	423.01-44-03	夹线螺母止动片	ROTATING STOPPER	(1)	(1)	
48	423.01-44-04	松线钉	TENSION RELEASE PIN ASM.	(1)	(1)	
49	423.01-44-05	夹线簧	TENSION SPRING	(1)	(1)	
50	423.01-44-06	夹线盘组件	THREAD TENSION DISK COMPL.	(1)	(1)	

1. 机头、外露部件 (1)

FRAME & MISCELLANEOUS COVER COMPONENTS (1)

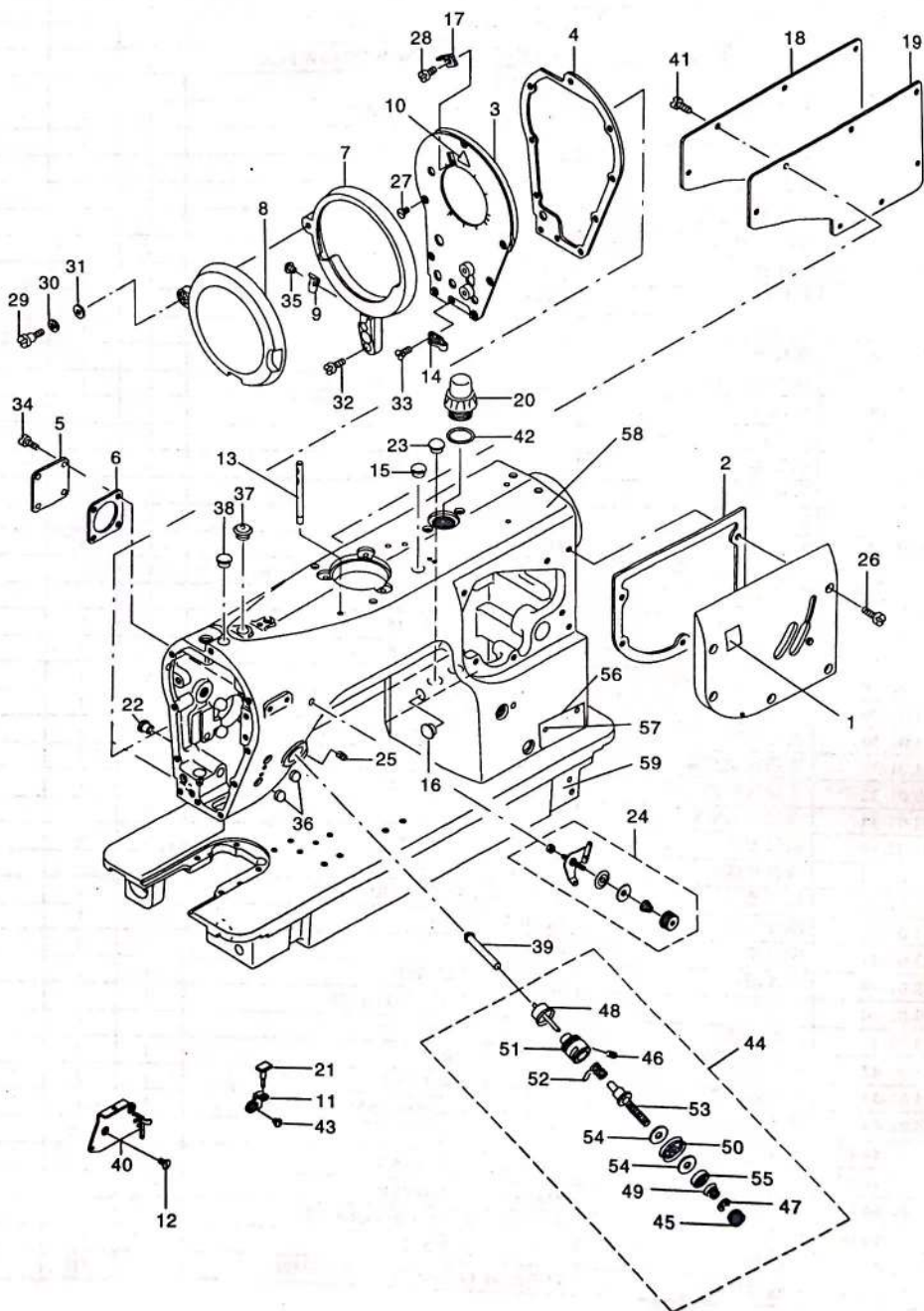

51	423.01-44-07	夹线座	THREAD TENSION ROD ASM.	(1)	(1)	备注
52	423.01-44-08	挑线簧	TAKE-UP SPRING	(1)	(1)	
53	423.01-44-09	夹线螺钉	THREAD TENSION POST ASM.	(1)	(1)	
54	423.01-44-10	毛毡	FELT	(2)	(2)	
55	423.01-44-11	夹线板	TENSION DISC HOLDER	(1)	(1)	
56	423.01-45	型号牌	MODEL PLATE	1	1	
57	423.01-46	铆钉	RIVET	2	2	
58	423.01-47	机壳	ARM	1	1	
59	423.01-48	底板	BED	1	1	

2、机座、外露盖板部件 (2)

FRAME & MISCELLANEOUS COVER COMPONENTS (2)

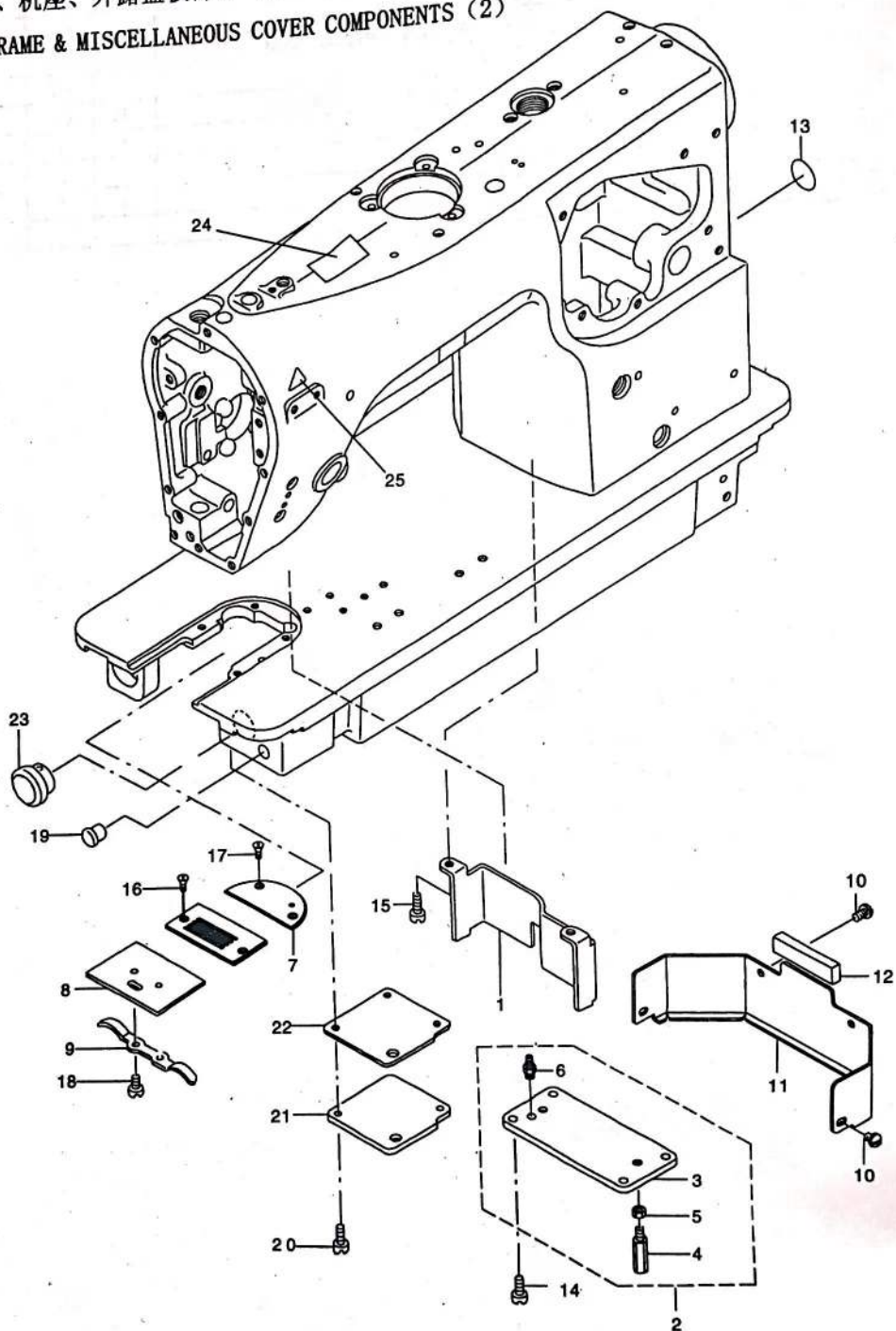

2、FRAME & MISCELLANEOUS COVER COMPONENTS (2)

2、机座、外露盖板部件 (2)

序号	图号	名称	DESCRIPTION	2284	2284-7	备注
1	423.02-01	支承板	SUPPORT PLATE	1	1	
2	423.02-02	螺旋齿轮箱盖组件	HELICAL GEAR BOX COVER ASM.	1	1	
3	423.02-02-01	螺旋齿轮箱盖	HELICAL GEAR BOX COVER	(1)	(1)	
4	423.02-02-02	底板支承螺钉	BED SCREW STUD	(2)	(2)	
5	423.02-02-03	底板支承螺母	NUT 5/16-24	(2)	(2)	
6	423.02-02-04	排油连接螺钉	CONNECTING SCREW	(1)	(1)	
7	423.02-03	半月板	BED PLATE	1	1	
8	423.02-04	推板	BED SLIDE	1		
9	423.02-05	推板簧	BED SLIDE SPRING	1		
10	423.02-06	防油罩板螺钉	SCREW 11/64-40 L=5	2	2	
11	423.02-07	防油罩板	OIL SHIELD PLATE	1	1	
12	423.02-08	防油橡胶	OIL SHIELD RUBBER	1	1	
13	423.02-09	接地标志	GROUND MARK	1	1	
14	423.02-10	齿轮箱盖螺钉	SCREW 11/64-40 L=9	4	4	
15	423.02-11	支承板螺钉	SCREW 11/64-40 L=12	2	2	
16	423.02-12	针板螺钉	SCREW 9/64-40 L=7.5	2	2	
17	423.02-13	半月板螺钉	SCREW 9/64-40 L=7.5	2	2	
18	423.02-14	推板簧螺钉	SCREW 3/32-56 L=1.9	2		
19	423.02-15	橡皮塞	RUBBER PLUG	1	1	
20	423.02-16	螺旋斜齿箱盖螺钉	SCREW 11/64-40 L=9	3	3	
21	423.02-17	螺旋斜齿箱盖	HELICAL BEVEL GEAR BOX COVER	1		
22	423.02-18	螺旋斜齿箱盖垫	GASKET	1	1	
23	423.02-19	尼龙塞	NYLON CAP	1	1	
24	423.02-20	注意不干胶	CAUTION LABEL	1	1	
25	423.02-21	安全标志	SAFETY LABEL	1	1	

3、机头、外露夹线部件 (3)

FRAME & MISCELLANEOUS COVER COMPONENTS (3)

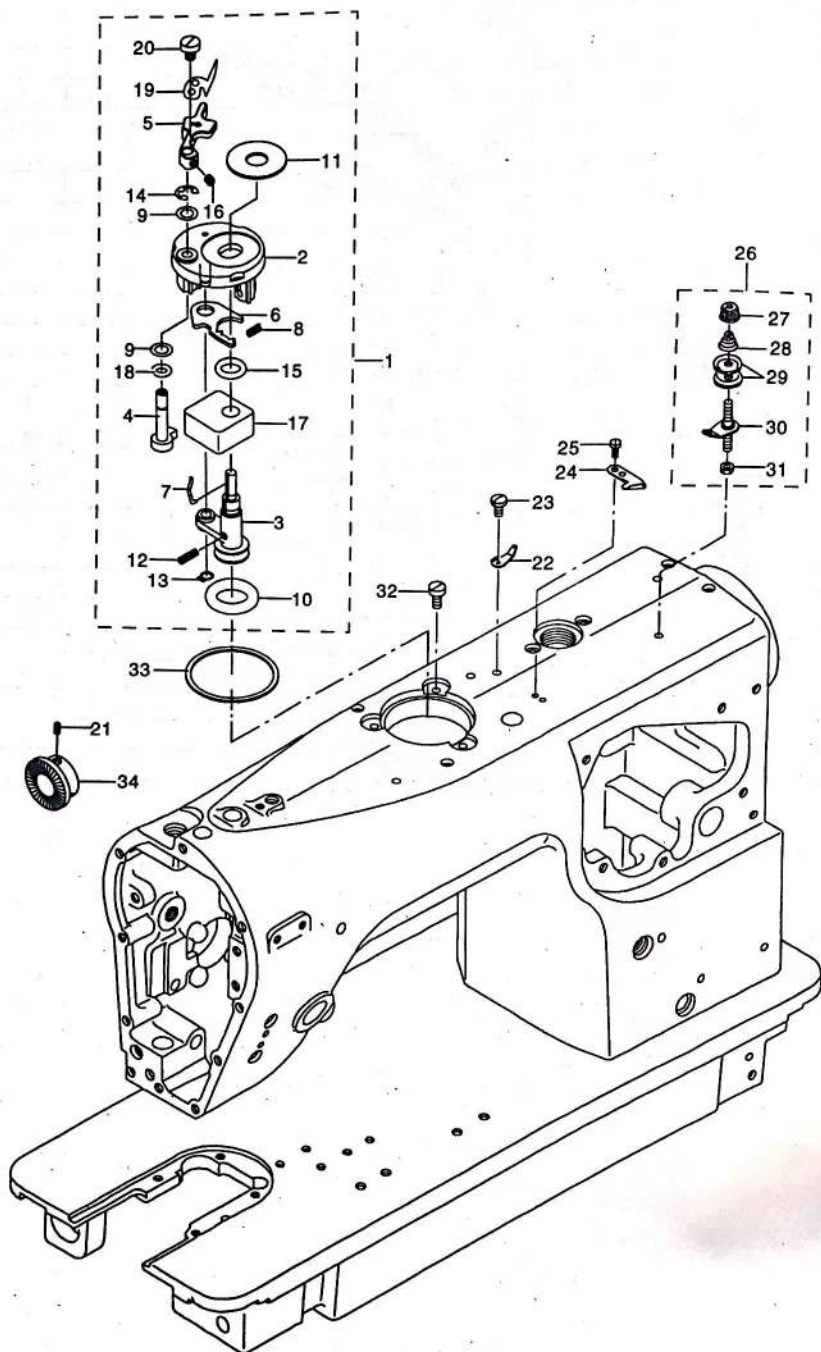

3、FRAME & MISCELLANEOUS COVER COMPONENTS (3)

3、机头、外露夹线部件 (3)

序号	图号	名称	DESCRIPTION	2284	2284-7	备注
1	423.03-01	绕线器组件	BOBBIN DEVICE ASM.	1	1	
2	423.03-01-01	绕线器座(组件)	BOBBIN FITTING BASIS COMPL.	(1)	(1)	
3	423.03-01-02	绕线轴组件	BOBBIN SHAFT COMPL.	(1)	(1)	
4	423.03-01-03	绕线凸轮轴(组件)	BOBBIN CAM SHAFT COMPL.	(1)	(1)	
5	423.03-01-04	绕线控制扳手	BOBBIN LEVER	(1)	(1)	
6	423.03-01-05	杠杆	ADJUSTING PLATE	(1)	(1)	
7	423.03-01-06	梭心防转弹簧	LATCH SPRING	(1)	(1)	
8	423.03-01-07	弹簧	PRESSUR FOOT SPRING	(1)	(1)	
9	423.03-01-08	垫片	VERTICAL ROLLER WASHER	(2)	(2)	
10	423.03-01-09	橡皮圈	RUBBER RING	(1)	(1)	
11	423.03-01-10	缓冲梭心垫	CUSHION	(1)	(1)	
12	423.03-01-11	绕线轴弹簧	SPRING	(1)	(1)	
13	423.03-01-12	轴用弹性挡圈	RETAINING RING	(1)	(1)	
14	423.03-01-13	开口挡圈	E-RING	(1)	(1)	
15	423.03-01-14	O形圈	RUBBER RING	(1)	(1)	
16	423.03-01-15	绕线控制扳手螺钉	SCREW 9/64-40 L=13	(1)	(1)	
17	423.03-01-16	蓄油海棉	OIL RESERVOER BASE	(1)	(1)	
18	423.03-01-17	O形圈	O-RING	(1)	(1)	
19	423.03-01-18	压线片	PUSH THREAD PLATE	(1)	(1)	
20	423.03-01-19	压线片螺钉	SCREW SM9/64-40 L=5	(1)	(1)	
21	423.03-02	绕线轮螺钉	SCREW 1/4-40 L=6	2	2	
22	423.03-03	导线器	THREAD GUIDE	1	1	
23	423.03-04	导线器螺钉	SCREW 11/64-40 L=7.8	1	1	
24	423.03-05	割线刀	THREAD CUTTER	1	1	
25	423.03-06	割线刀螺钉	SCREW 9/64-40 L=6	2	2	
26	423.03-07	绕线器夹线器组件	BOBBIN THREAD TENSION ASM.	1	1	
27	423.03-07-01	夹线螺母	THREAD TENSION NUT	(1)	(1)	
28	423.03-07-02	夹线弹簧	THREAD TENSION SPRING	(1)	(1)	
29	423.03-07-03	夹线板	BOBBIN WINDER TENSION DISC	(2)	(2)	
30	423.03-07-04	夹线螺柱组件	BOBBING THREAD TENSION ROD ASM.	(1)	(1)	
31	423.03-07-05	夹线螺柱螺母	NUT 11/64-40	(1)	(1)	
32	423.03-08	绕线器固定螺钉	SCREW 3/16-28 L=10	3	3	
33	423.03-09	垫圈	PACKING	1	1	
34	423.03-10	绕线轮	DRIVING WHEEL	1	1	

4、上轴、针杆部件

4、MAIN SHAFT & NEEDLE BAR COMPONENTS

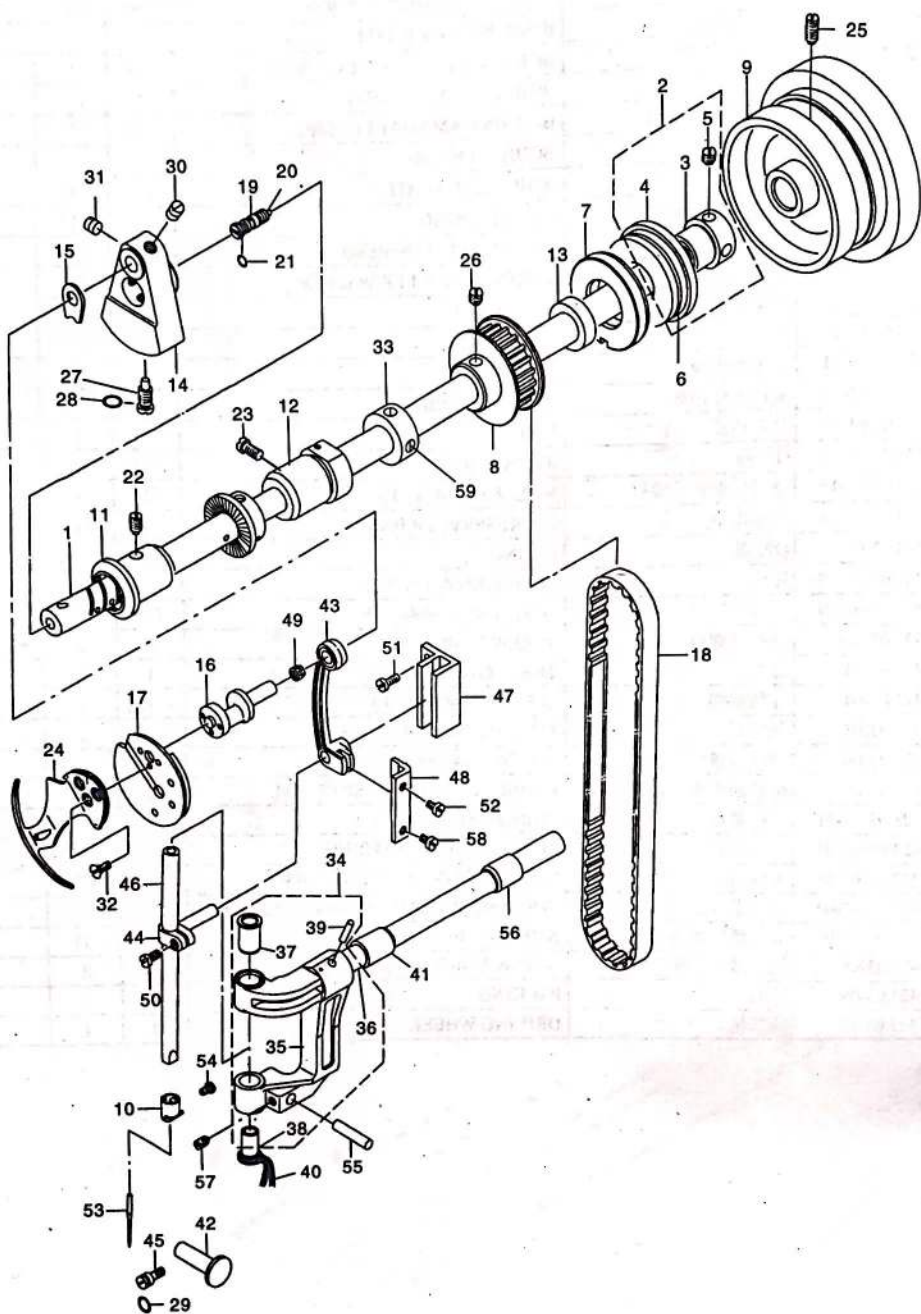

4、MAIN SHAFT & NEEDLE BAR COMPONENTS

4、上轴、针杆部件

序号	图号	名称	DESCRIPTION	2284	2284-7	备注
1	423.04-01	主轴	MAIN SHAFT	1	1	
2	423.04-02	挡圈组件	THRUST COLLAR ASM.	1	1	
3	423.04-02-01	挡圈	THRUST COLLAR	(1)	(1)	
4	423.04-02-02	轴承	BEARING D=20×47	(1)	(1)	
5	423.04-02-03	挡圈螺钉	SCREW 1/4-40 L=6	(2)	(2)	
6	423.04-02-05	油封	OIL SEAL	1	1	
7	423.04-03	油封挡圈	OIL SEAL COLLAR	1	1	
8	423.04-04	上轴同步轮	SPROCKET	1	1	
9	423.04-05	上轮	HAND WHEEL	1		
10	423.04-06	针杆过线勾	NEEDLE ROD THREAD RACK	1	1	
11	423.04-07	主轴前套筒	MAIN SHAFT BUSHING .FORNT	1	1	
12	423.04-08	主轴中套筒	MAIN SHAFT BUSHING .INTERMEDIA	1	1	
13	423.04-09	油封	OIL SEAL	1	1	
14	423.04-10	针杆曲柄	COUNTER WEIGHT	1	1	
15	423.04-11	针杆曲柄轴承垫圈	COUNTER WEIGHT PROTECTING PLATE	1	1	
16	423.04-12	挑线曲柄	NEEDLE BAR CRANK	1	1	
17	423.04-13	平衡盘组件	TAKE-UP COUNTER WEIGHT ASM.	1	1	
18	423.04-14	同步带	TIMING BELT	1	1	
19	423.04-15	销	PIN	1	1	
20	423.04-16	油芯	OIL WICK	1	1	
21	423.04-17	O型圈	RUBBER RING	1	1	
22	423.04-18	主轴前套筒螺钉	SCREW 15/64-28 L=10.5	1	1	
23	423.04-19	主轴中套筒螺钉	SCREW 15/64-28 L=11	1	1	
24	423.04-20	旋转挑线杆	BALANCE V	1	1	
25	423.04-21	上轮主头螺钉	SCREW 15/64-28 L=15	2	2	
26	423.04-22	上轴同步轮主头螺钉	SCREW 1/4-40 L=6	2	2	
27	423.04-23	针杆曲柄螺钉	SCREW 9/32-28 L=16	1	1	
28	423.04-24	O型圈	RUBBER RING	1	1	
29	423.04-25	O型圈	RUBBER RING	1	1	
30	423.04-26	挑线曲柄螺钉	SCREW 1/4-40 L=6	2	2	
31	423.04-27	针杆曲柄螺钉	SCREW 9/32-28 L=7	1	1	
32	423.04-28	旋转挑线杆螺钉	SCREW 9/64-40 L=8.6	3	3	
33	423.04-29	挡圈	THRUST COLLAR ASM.D=14.72 W=12	1	1	
34	423.04-30	针杆摆动组件	NEEDLE BAR YOKE ASM.	1	1	
35	423.04-30-01	针杆摆动架	NEEDLE BAR YOKE	(1)	(1)	
36	423.04-30-02	摆动架轴	SHAFT	(1)	(1)	
37	423.04-30-03	针杆套(上)	NEEDLE BAR BUSHING ,UPPER D=7	(1)	(1)	
38	423.04-30-04	针杆套(下)	NEEDLE BAR BUSHING ,LOWER D=7	(1)	(1)	
39	423.04-30-05	弹簧销	SPRING PIN	(1)	(1)	
40	423.04-31	油线	OIL WICK	0.1	0.1	
41	423.04-32	摆动架轴前套	FEED ROCKER SHAFT BUSHING	1	1	
42	423.04-33	针杆摆动限位销	NEEDLE BAR YOKE PRESSER	1	1	
43	423.04-34	曲柄连杆组件	NEEDLE BAR CRANK ROD ASM.	1	1	
44	423.04-35	针杆连接柱	NEEDLE BAR CONNECTION	1	1	
45	423.04-36	针杆摆动限位销螺钉	SCREW	1	1	
46	423.04-37	针杆	NEEDLE ROD	1	1	
47	423.04-38	针杆连接柱导轨	NEEDLE BAR CONNECTION GUIDE	1	1	
48	423.04-39	曲柄连杆导轨	CTANK ROD GUIDE	1	1	
49	423.04-40	连杆轴承	NEEDLE BEARING ,A	1	1	
50	423.04-41	针杆连接柱螺钉	SCREW 9/64-40 L=8.5	1	1	
51	423.04-42	导轨螺钉	SCREW 11/64-40 L=9	2	2	
52	423.04-43	导轨螺钉(短)	SCREW 11/64-40 L=7	1	1	
53	423.04-44	机针	NEEDLE 438 #75	1	1	
54	423.04-45	针杆过线勾螺钉	SCREW 1/8-44 L=4.9	1	1	
55	423.04-46	针杆摆动架导向销	GUIDE PIN	1	1	
56	423.04-47	针杆摆动架后套	SHAFT BUSHING ,REAR	1	1	
57	423.04-48	针杆摆动架导向销螺钉	SCREW 3/16-28 L=7	1	1	
58	423.04-49	导轨螺钉(长)	SCREW 11/64-40 L=10	1	1	
59	423.04-50	挡圈螺钉	SCREW	2	2	

5. 摆针部件(1)

NEEDLE VIBRATOR & ADJUSTMENT COMPONENTS (1)

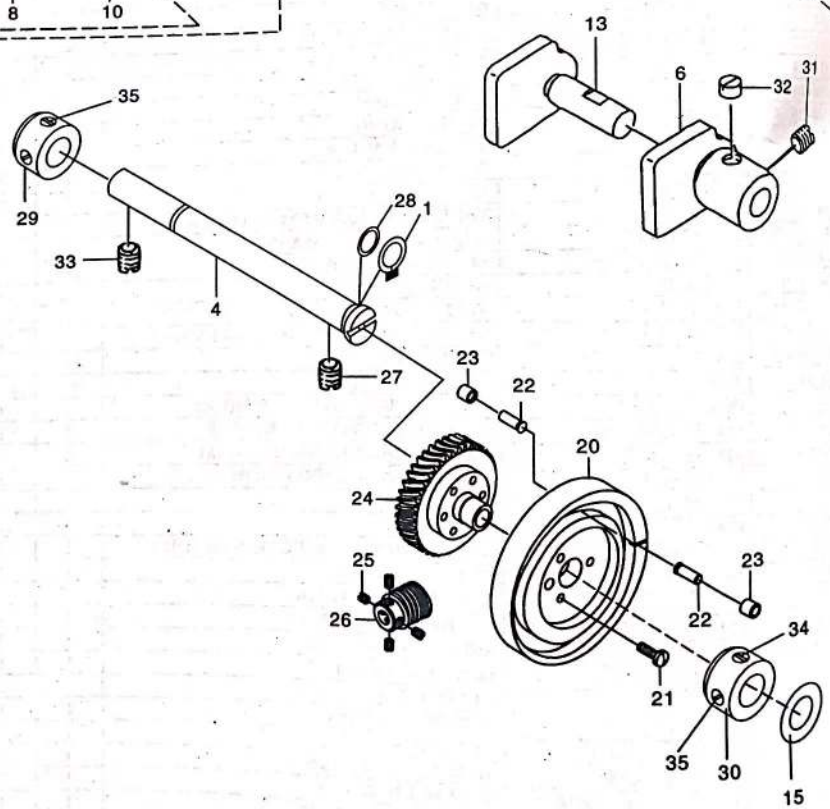
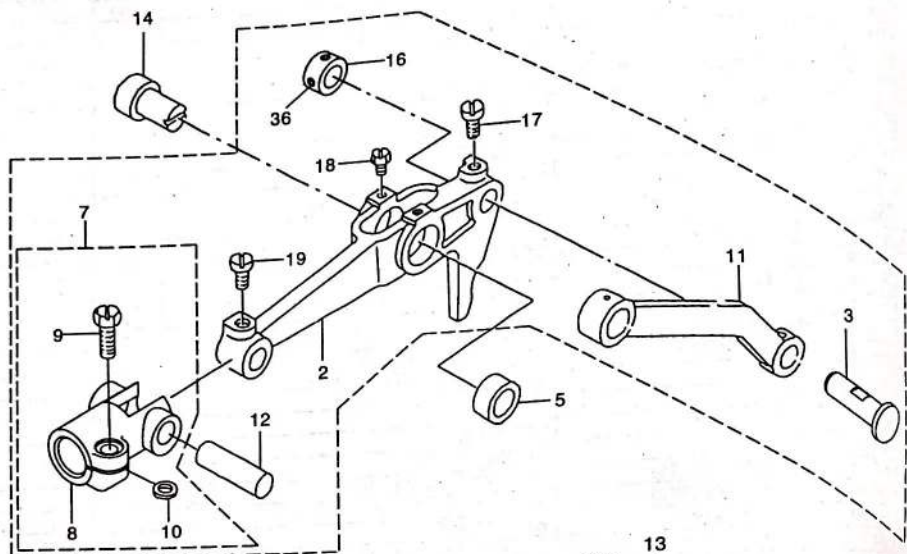

5.摆针部件(1)

5.NEEDLE VIBRATOR & ADJUSTMENT COMPONENTS(1)

序号	图号	名称	DESCRIPTION	2284	2284-7	备注
1	423.05-01	开口环	SNAPRING M10	1	1	
2	423.05-02	针杆摆动连杆	DRIVE LINK ASM.	1	1	
3	423.05-03	摆针传转连杆销	LINK	1	1	
4	423.05-04	摆针凸轮轴	NEEDLE VIBRATING CAM SHAFT	1	1	
5	423.05-05	针杆摆动连杆套	BUSHING	1	1	
6	423.05-06	摆动连杆导向块A	DRIVE LINK GUIDE A	1	1	
7	423.05-07	针杆摆动轴座组件	SHAFT CONNECTION ASM.	1	1	
8	423.05-07-01	针杆摆动轴座	SHAFT CONNECTION	(1)	(1)	
9	423.05-07-02	针杆摆动轴座螺钉	SCREW 3/16-28 L=14	(1)	(1)	
10	423.05-07-03	垫片	WASHER 5.1X7.5X0.5	(1)	(1)	
11	423.05-08	摆针传动连杆	LINK	1	1	
12	423.05-09	针杆摆动轴座销	PIN D	1	1	
13	423.05-10	摆动连杆导向块B	DRIVE LINK GUIDE B	1	1	
14	423.05-11	针杆摆动连杆轴	PIN A	1	1	
15	423.05-12	垫圈	WASHER	1	1	
16	423.05-13	挡圈	THRUST COLLAR	1	1	
17	423.05-14	摆针传动连杆螺钉	SCREW 11/64-40 L=8.5	1	1	
18	423.05-15	针杆摆动连杆轴螺钉	SCREW 9/64-40 L=5.5	2	2	
19	423.05-16	针杆摆动连杆螺钉	SCREW 11/64-40 L=8.5	1	1	
20	423.05-17	针迹凸轮	NEEDLE CAM	1	1	
21	423.05-18	针迹凸轮螺钉	SCREW 11/64-40 L=14	3	3	
22	423.05-19	针迹凸轮滚轮轴	NEEDLE CAM ROLLER SHAFT	2	2	
23	423.05-20	针迹凸轮滚柱	NEEDLE CAM ROLLER A	2	2	
24	423.05-21	蜗轮	WORM WHEEL COMPL	1	1	
25	423.05-22	蜗杆螺钉	SCREW 1/4-40 L=6	4	4	
26	423.05-23	蜗杆	WORM A	1	1	
27	423.05-24	摆针凸轮轴螺钉	SCREW 1/4-40 L=8.5	1	1	
28	423.05-25	橡皮圈	RUBBER RING	1	1	
29	423.05-26	挡圈	THRUST COLLAR ASM.D=10.32 W=1	1	1	
30	423.05-27	挡圈	THRUST COLLAR ASM.D=10.32 W=1	1	1	
31	423.05-28	摆动连杆导向块A螺钉	SCREW 15/64-28 L=7	1	1	
32	423.05-29	摆动连杆导向块A螺钉	SCREW 1/4-40 L=4.2	1	1	
33	423.05-30	摆针凸轮轴螺钉	SCREW 1/4-40 L=8.5	1	1	
34	423.05-31	挡圈螺钉	SCREW 1/4-40 L=10	1	1	
35	423.05-32	挡圈螺钉	SCREW 1/4-40 L=6	3	3	
36	423.05-33	挡圈螺钉	SCREW 9/64-40 L=5	2	2	

6.摆针部件(2)

6.NEEDLE VIBRATOR & ADJUSTMENT COMPONENTS(2)

序号	图号	名称	DESCRIPTION	2284	2284-7	备注
1	423.06-01	针位调节底座	NEEDLE POSITION CHANGE BASE	1	1	
2	423.06-02	针位调节底座螺钉	HINGE SCREW D=8 H=4	1	1	
3	423.06-03	波型垫圈	WAVED WASHER 8.5X12.5X0.3	3	3	
4	423.06-04	螺母	NUT 15/64-28	1	1	
5	423.06-05	针杆调节固定板	CHANGE BASE FITTING PLATE	1	1	
6	423.06-06	机臂	ARM	1	1	
7	423.06-07	摆针变位轴	SHAFT	1	1	
8	423.06-08	摆针变位轴螺钉	SCREW 9/64-40 L=6	3	3	
9	423.06-09	垫圈	WASHER	2	2	
10	423.06-10	波形垫圈	WAVED WASHER	1	1	
11	423.06-11	开口挡圈	SNAP RING M10.	1	1	
12	423.06-12	机臂销	SHAFT	1	1	
13	423.06-13	螺母	NUT 15/64-28	1	1	
14	423.06-14	限位器组件	STOPPER ASM.	1	1	
15	423.06-15	卡簧	E-RING	1	1	
16	423.06-16	螺母	NUT	1	1	
17	423.06-17	止动螺母	NUT STOPPER	1	1	
18	423.06-18	杠杆组件	LEVER ASM.	1	1	
19	423.06-19	卡簧	E-RING 4	1	1	
20	423.06-20	滚珠	HAND STOP CRANK SHAFT BALL	1	1	
21	423.06-21	弹簧	SPRING	1	1	
22	423.06-22	油封	OIL SHIELD	1	1	
23	423.06-23	止动螺母螺钉	SCREW 9/64-40 L=5.0	1	1	
24	423.06-24	密封垫	PACKING	1	1	
25	423.06-25	挡圈	ROLLER	1	1	
26	423.06-26	针位调节螺钉	ADJUSTING PICK-UP SCREW	1	1	
27	423.06-27	针位锁紧螺母	ADJUSTING PICK-UP	1	1	
28	423.06-28	针位锁紧螺母螺钉	SCREW M4 X0.7 L=5	2	2	
29	423.06-29	摆针旋钮	KNOB	1	1	
30	423.06-30	摆针旋钮限位挡圈	LEVER STOPPER	2	2	
31	423.06-31	摆针旋钮螺钉	SCREW 9/64-40 L=6	2	2	
32	423.06-32	摆针旋钮垫圈	WASHER	2	2	
33	423.06-33	摆针旋钮杠杆	LEVER	1	1	
34	423.06-34	刻度盘组件	SCALE PLATE ASM.	1	1	
35	423.06-34-01	刻度盘	SCALE PLATE	(1)	(1)	
36	423.06-34-02	刻度盘安装板	SCALE MOUNTING BASE COMPL.	(1)	(1)	
37	423.06-34-03	刻度盘螺钉	SCREW 1/8-44 L-2.5	(2)	(2)	
38	423.06-35	机壳前盖板	SIDE COVER ASM.	1	1	
39	423.06-36	刻度拨盘	LEVER	1	1	
40	423.06-37	刻度拨盘手柄	KNOB	1	1	
41	423.06-38	刻度拨盘止动环	LEVER STOPPER	2	2	
42	423.06-39	刻度拨盘螺钉	SCREW 9/64-40 L=3.5	2	2	
43	423.06-40	刻度拨盘垫圈	WASHER 3.7X8X1	2	2	
44	423.06-41	限位键	KEY	1	1	
45	423.06-42	弹簧	SPRING	1	1	
46	423.06-43	针杆调节固定板螺钉	SCREW 3/16-28 L=10	4	4	
47	423.06-44	摆针旋钮杠杆螺钉	SCREW 9/64-40 L=8.5	1	1	
48	423.06-45	摆针旋钮螺钉	SCREW 3/16-32 L=6.5	1	1	
49	423.06-46	垫圈	WASHER	1	1	
50	423.06-47	波形垫圈	WAVED WASHER 8.5X12.5X0.3	2	2	
51	423.06-48	垫片	WASHER	1	1	
52	423.06-49	垫片	WASHER 3.7X6X1	1	1	

7. 摆针凸轮转换部件(3)

NEEDLE VIBRATOR CAM CHANGED COMPONENTS(3)

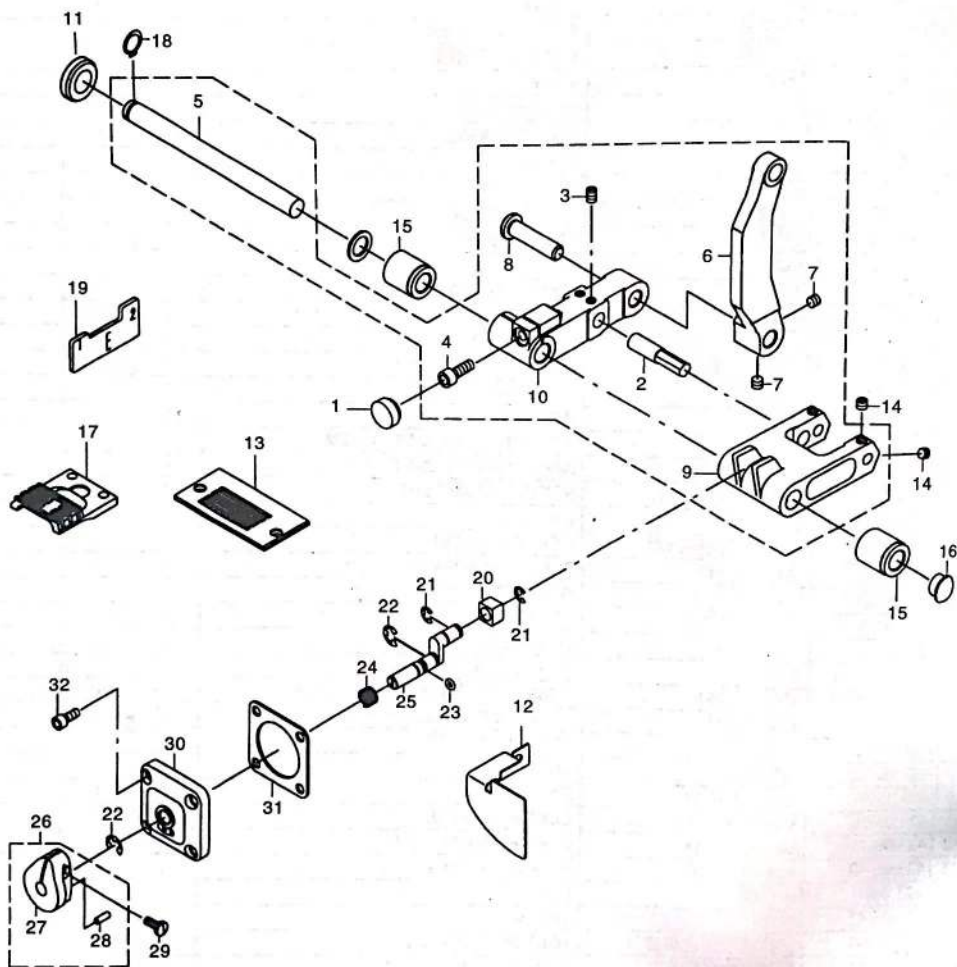

7.摆针凸轮转换部件

7.NEEDLE VIBRATOR CAM CHANGED COMPONENTS(3)

序号	图号	名称	DESCRIPTION	2284	2284-7	备注
1	423.07-01	橡皮塞	RUBBER PLUG	1	1	
2	423.07-02	销	DIA PIN A	1	1	
3	423.07-03	针杆摆动臂销螺钉	SCREW M5X6	2	2	
4	423.07-04	针杆摆动臂螺钉	SCREW M5X0.8 L=14	1	1	
5	423.07-05	针杆摆动轴	NEEDLE DRIVING SHAFT	1	1	
6	423.07-06	机针摆动杆	NEEDLE DRIVING ROD	1	1	
7	423.07-07	机针摆动杆螺钉	SCREW M5 L=4	2	2	
8	423.07-08	针杆摆动臂销	THREAD TRIMMER SHAFT	1	1	
9	423.07-09	摆针凸轮臂	NEEDLE CAM ARM	1	1	
10	423.07-10	摆针摆动臂	NEEDLE DRIVING ARM	1	1	
11	423.07-11	橡皮塞	RUBBER PLUG	1	1	
12	423.07-12	防油板	OIL SHIELD	1	1	
13	423.07-13	针板	NEEDLE PLATE	1	1	
14	423.07-14	摆针凸轮臂螺钉	SCREW M5 L=4	4	4	
15	423.07-15	摆针轴前后套	METAL,FRONT	2	2	
16	423.07-16	橡皮塞	PLUG	1	1	
17	423.07-17	送布牙	FEED DOG	1	1	
18	423.07-18	止动环	SNAP RING M10	1	1	
19	423.07-19	同步板	TIMING GAUGE E	1	1	
20	423.07-20	滑块	ROLLER	1	1	
21	423.07-21	卡簧	E-RING4	2	2	
22	423.07-22	卡簧	E-RING	2	2	
23	423.07-23	O型圈	RUBBER RING	1	1	
24	423.07-24	弹簧	SPRING	1	1	
25	423.07-25	变换滑动轴	CHANGE OVER SLIDE SHAFT	1	1	
26	423.07-26	变换杆组件	CHANGE OVER LEVER ASM.	1	1	
27	423.07-26-01	变换杆	CHANGE OVER LEVER	(1)	(1)	
28	423.07-26-02	限位销	PIN	(1)	(1)	
29	423.07-27	变换杆螺钉	SCREW 9/64-40 L=8.5	1	1	
30	423.07-28	变换座	CHANGE OVER BASIS	1	1	
31	423.07-29	密封垫	GASKET	1	1	
32	423.07-30	变换座螺钉	SCREW	4	4	

8. 压脚部件

PRESSER BAR & FEED REGULATOR COMPONENTS

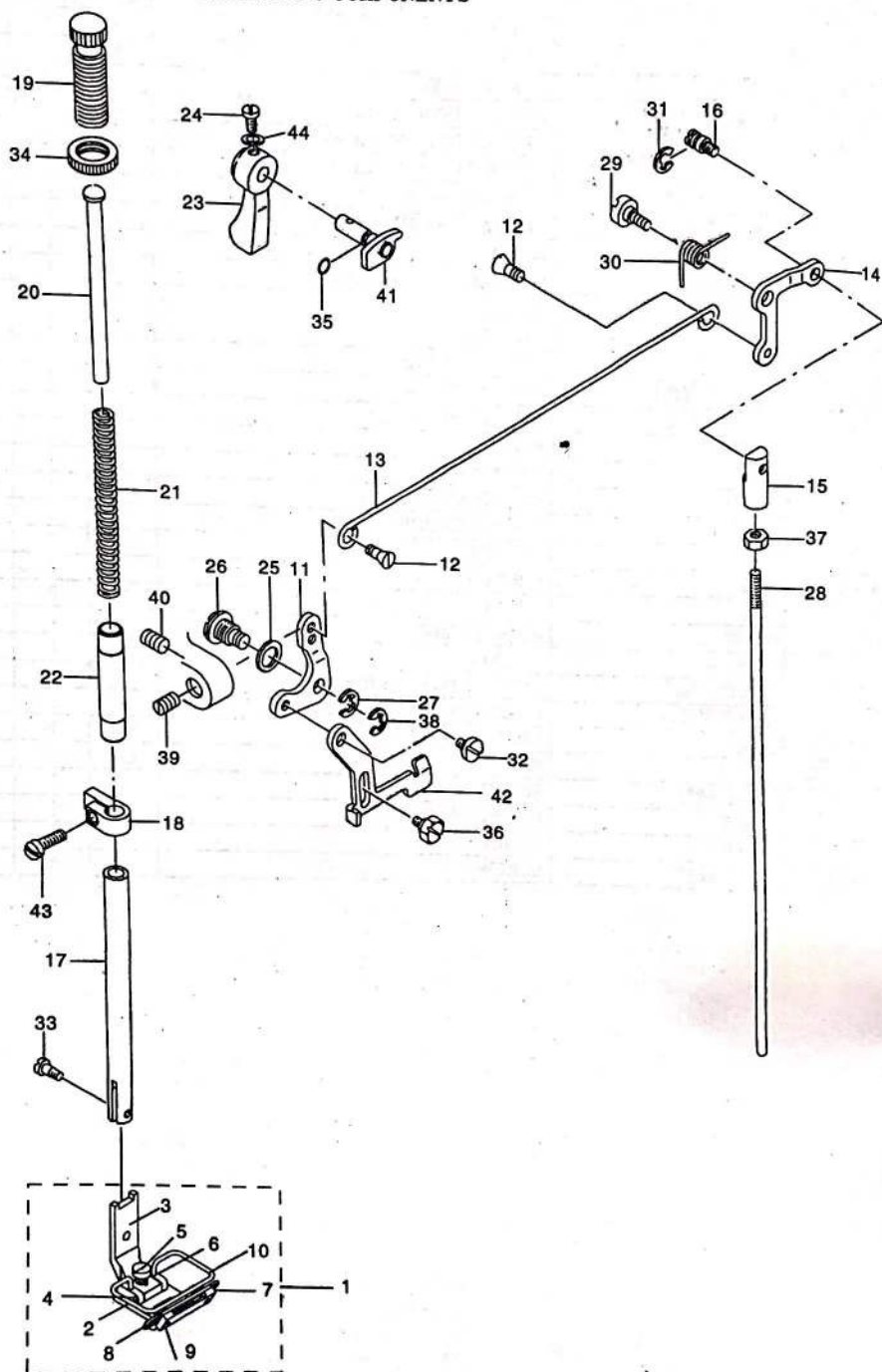

8. 压脚部件

8. PRESSER BAR & FEED REGULATOR COMPONENTS

序号	图号	名称	DESCRIPTION	2284	2284-7	备注
1	423.08-01	压脚组件	PRESSER FOOT ASM.	1		
2	423.08-01-01	压脚底板	PRESSER FOOT MOTHERBOARD	(1)		
3	423.08-01-02	压脚柄	PRESSER FOOT POWER	(1)		
4	423.08-01-03	压脚销	PRESSER FOOT PIN	(1)		
5	423.08-01-04	压脚螺钉	PRESSER FOOT SCREW	(1)		
6	423.08-01-05	压脚弹簧	PRESSER FOOT SPRING	(1)		
7	423.08-01-06	夹带压板	CARRY SECRETLY PLATE	(1)		
8	423.08-01-07	带槽宽度调节板	BREADTH ADJUSTING PLATE	(1)		
	423.08-01-07a	带槽宽度调节板	BREADTH ADJUSTING PLATE	(1)		
9	423.08-01-08	带槽宽度调节板螺钉	SCREW	(2)		
10	423.08-01-09	护指架	FINGER COVER	(1)		
11	423.08-02	抬压脚前杠杆	LIFTING LEVER LINK	1	1	
12	423.08-03	铰链螺钉	HINGE SCREW	2	1	
13	423.08-04	抬压脚拉杆	LIFTING LEVER CONNECTING ROD	1	1	
14	423.08-05	抬压脚后杠杆	LIFTING LEVER LINK ARM	1	1	
15	423.08-06	调节螺柱	SWIVEL	1	1	
16	423.08-07	抬压脚后杠杆螺钉	CONNECTING ROD HINGE SCREW	1	1	
17	423.08-08	压杆	PRESSER BAR	1	1	
18	423.08-09	压杆导架	PRESSER BAR GUIDE BRACKET	1	1	
19	423.08-10	调压螺钉	PRESSER SPRING REGULATOR	1	1	
20	423.08-11	压脚导柱	PRESSER GUIDE BAR	1	1	
21	423.08-12	调压簧	PRESSER SPRING REGULATOR	1	1	
22	423.08-13	压杆下套	PRESSER BAR BUSHING, LOWER	1	1	
23	423.08-14	压脚扳手	HAND LIFTER CAM COMPL.	1	1	
24	423.08-15	压脚扳手螺钉/垫片	SCREW 9/64-40 L=9.5	1	1	
25	423.08-16	铰链螺钉密封圈	LIFTING LEVER GASKET	1	1	
26	423.08-17	铰链螺钉	HINGE PIN	1	1	
27	423.08-18	卡簧	E-RING	1	1	
28	423.08-19	抬压脚顶杆	LIFTING LEVER	1	1	
29	423.08-20	抬压脚后杠杆铰链螺钉	KNEE LIFTING LINK STEP-SCREW	1	1	
30	423.08-21	抬压脚后杠杆弹簧	KNEE LIFTING LINK SPRING	1	1	
31	423.08-22	卡簧	E-RING	1	1	
32	423.08-23	铰链螺钉	HINGE SCREW D=6.35 H=3	1	1	
33	423.08-24	压脚螺钉	SCREW 9/64-40 L=8.5	1	1	
34	423.08-25	螺压螺母	NUT	1	1	
35	423.08-26	O型圈	RUBBER RING	1	1	
36	423.08-27	铰链螺钉	HINGE SCREW D=6.35 H=2.7	1	1	
37	423.08-28	抬压脚顶杆调节螺母	NUT 3/16-32	1	1	
38	423.08-29	卡簧	E-RING	1	1	
39	423.08-30	压脚浮动调节螺钉	SCREW	1	1	
40	423.08-31	压脚浮动锁定螺钉	SCREW 15/64-28 L=4.7	1	1	
41	423.08-32	抬压脚凸轮组件	HAND LIFTER CAM COMPL.	1	1	
42	423.08-33	压脚升降板	LIFTING LEVER	1	1	
43	423.08-34	压紧导架螺钉	SCREW 11/64-40 L=10.5	1	1	
44	423.08-35	压脚扳手螺钉垫片	WASHER	1	1	

9. 倒针部件

FEED MECHANISM & CONDENSE COMPONENTS

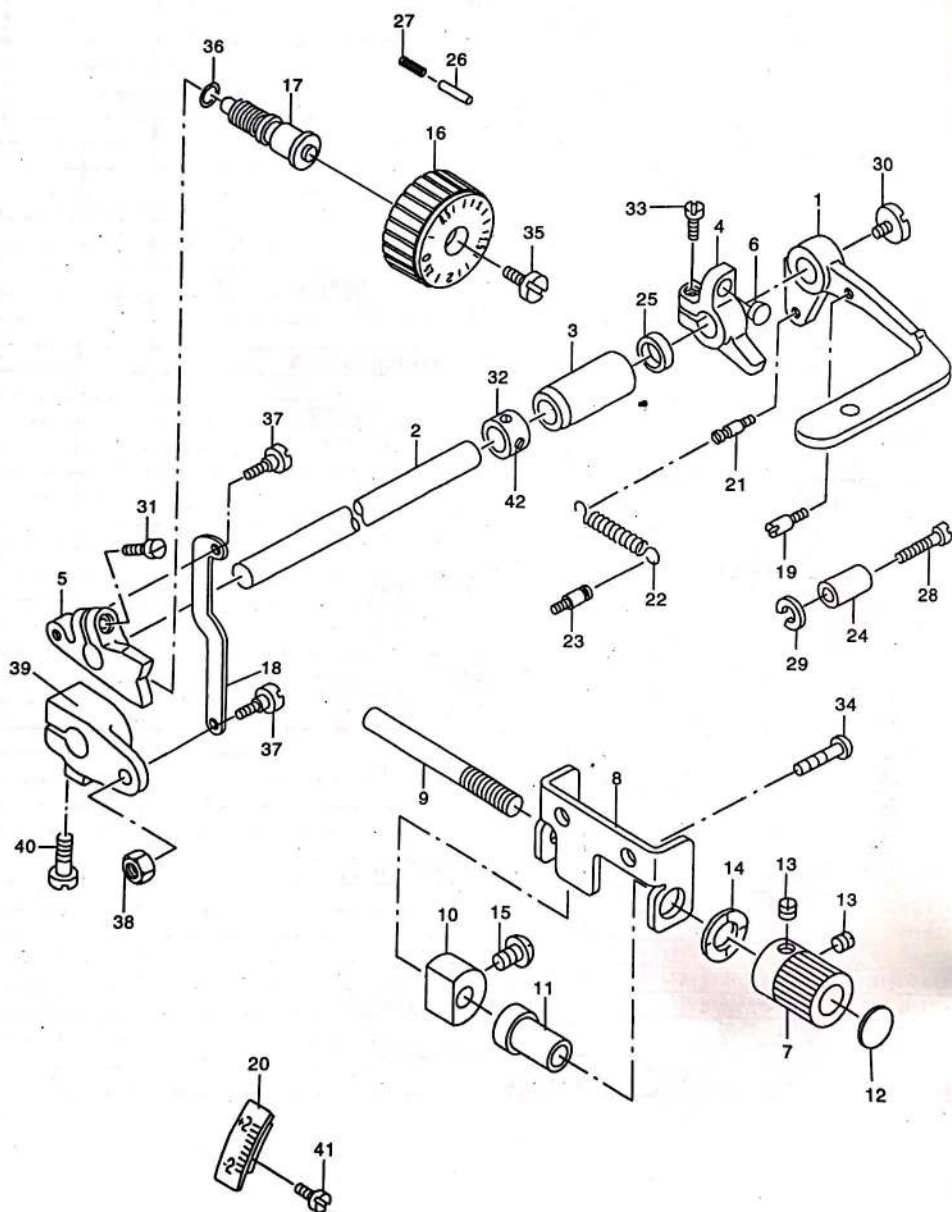

9.倒针部件(2)

9.FEED MECHANISM & CONDENSE COMPONENTS

序号	图号	名称	DESCRIPTION	2284	2284-7	备注
1	423.09-01	倒针扳手	LEVER	1	1	
2	423.09-02	倒针扳手轴	SHAFT	1	1	
3	423.09-03	倒针扳手轴套	BUSHING	1	1	
4	423.09-04	倒缝限位曲柄	CONDENSE STOPPER ARM ASM.	1	1	
5	423.09-05	送料调节器	FEED DRIVING ADJUSTER	1	1	
6	423.09-06	倒针扳手限位曲柄尼龙塞	NYLON PLUG	1	1	
7	423.09-07	旋钮	KNOB	1	1	
8	423.09-08	调节螺杆底板	ADJUSTING SCREW BASE	1	1	
9	423.09-09	调节螺杆	ADJUSTING SCREW	1	1	
10	423.09-10	限位器	STOPPER	1	1	
11	423.09-11	调节螺套	SHAFT	1	1	
12	423.09-12	刻度板	STOPPER DIAL PLATE	1	1	
13	423.09-13	旋扭螺钉	SCREW 11/64-40 L=3.5	2	2	
14	423.09-14	波形垫圈	WAVED WASHER	1	1	
15	423.09-15	限位器螺钉	SCREW 11/64-40 L=7	1	1	
16	423.09-16	针距标盘	FEED DIAL	1	1	
17	423.09-17	调节螺杆	ADJUSTING SCREW	1	1	
18	423.09-18	倒送料连杆	FEED REVERSAL LINK	1	1	
19	423.09-19	限位销	PIN	1	1	
20	423.09-20	刻度盘	SCALE PLATE	1	1	
21	423.09-21	拉簧销	SPRING SUSPENSION	1	1	
22	423.09-22	拉簧	TORSION SPRING	1	1	
23	423.09-23	拉簧销	TENSION SPRING RACK B	1	1	
24	423.09-24	倒送料扳手限位器	REVERSE FEED LEVER STOPPER	1	1	
25	423.09-25	油封	OIL SEAL	1	1	
26	423.09-26	限位钉	PIN	1	1	
27	423.09-27	弹簧	SPRING	1	1	
28	423.09-28	螺钉	SCREW 3/16-28 L=14	1	1	
29	423.09-29	弹簧垫圈	SPRING WASHER 5.1X9.2X1.3	1	1	
30	423.09-30	螺钉	SCREW 3/16-32 L=6.5	1	1	
31	423.09-31	螺钉	SCREW 3/16-28 L=14	1	1	
32	423.09-32	倒送扳手轴挡圈	THRUST COLLAR ASM D=10.32 W=1	1	1	
33	423.09-33	倒送限位曲柄螺钉	SCREW 3/16-28 L=14	1	1	
34	423.09-34	调节螺杆底座螺钉	SCREW 3/16-28 L=6	2	2	
35	423.09-35	针距标盘螺钉	SCREW 3/16-28 L=18	1	1	
36	423.09-36	O型圈	RBBER RING	1	1	
37	423.09-37	倒送料连杆铰链螺钉	HINGE SCREW D=6, H=3.2	2	2	
38	423.09-38	倒送料连杆螺母	NUT 3/16-28	1	1	
39	423.09-39	倒送料曲柄	FEED VARIABLE ARM B	1	1	
40	423.09-40	倒送料曲柄螺钉	SCREW 3/16-28 L=15.5	1	1	
41	423.09-41	刻度盘螺钉	SCREW 3/16-28 L=6	2	2	
42	423.09-42	倒顺扳手轴挡圈螺钉	SCREW	2	2	

10. 送料、拾牙部件

FEED MECHANISM COMPONENTS

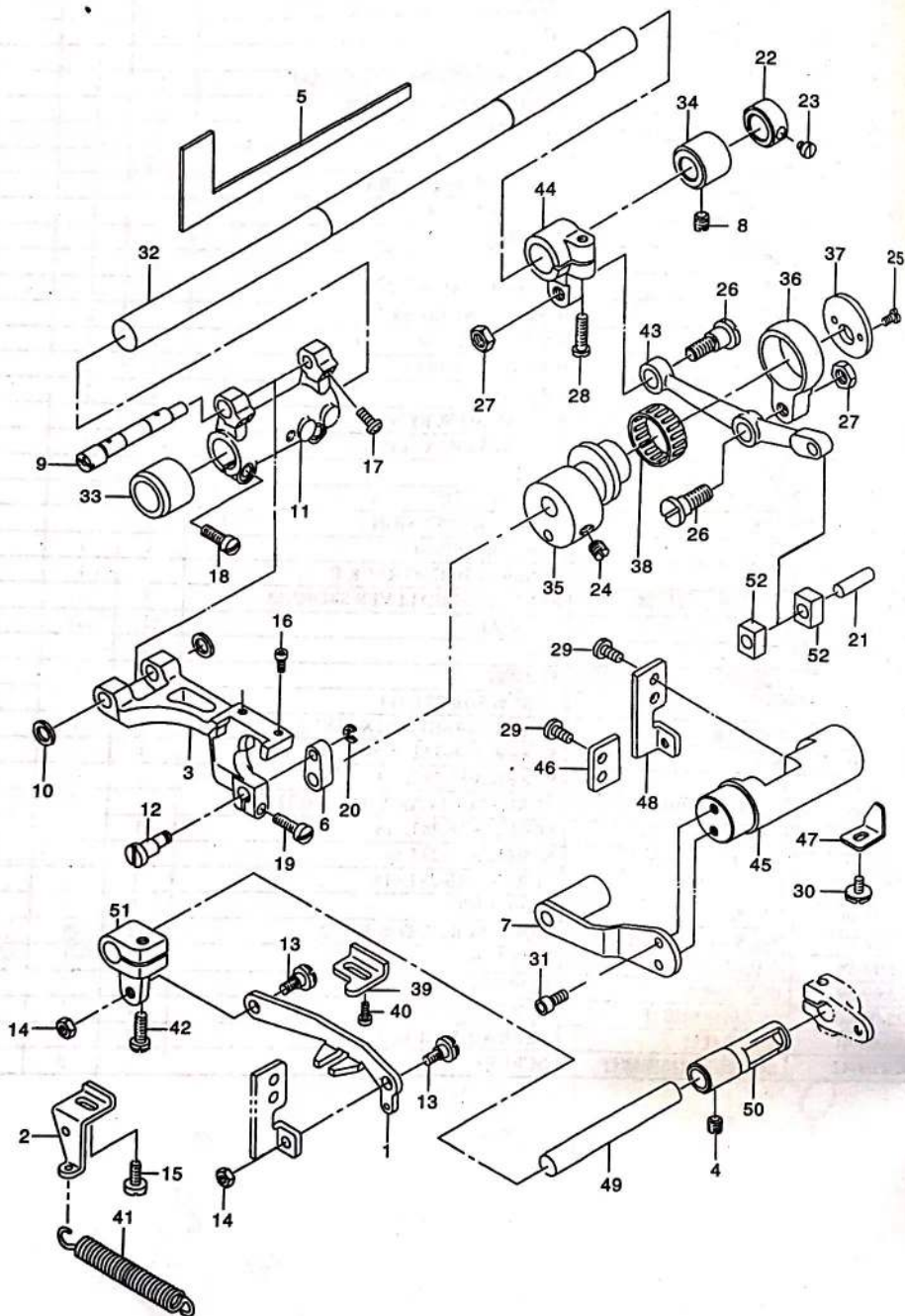

10.送料抬牙部件(2)

10.FEED MECHANISM COMPONENTS

序号	图号	名称	DESCRIPTION	2284	2284-7	备注
1	423.10-01	倒送料调节器连杆	FEED REVERSAL LINK	1	1	
2	423.10-02	拉力弹簧架	TENSION SPRING RACK	1	1	
3	423.10-03	送料牙架	FEED BASE	1	1	
4	423.10-04	送料可变轴套螺钉	SCREW 15/64-28 L=4.7	1	1	
5	423.10-05	羊毛毡	FELT	1	1	
6	423.10-06	抬牙小连杆	LINK	1	1	
7	423.10-07	平衡重量组件	BALANCE WEIGHT COMPL.	1	1	
8	423.10-08	送料轴后套螺钉	SCREW 15/64-28 L=7	1	1	
9	423.10-09	牙架偏心销	FEED BASE SHAFT	1	1	
10	423.10-10	送料牙架间隙垫片	SPACER	2	2	
11	423.10-11	送料牙架曲柄	FEED POCKER	1	1	
12	423.10-12	抬牙偏心销	LINK SHAFT	1	1	
13	423.10-13	铰链螺钉	HINGE SCREW D=6 H=3.2	2	2	
14	423.10-14	螺母	NUT 3/16-28	2	2	
15	423.10-15	拉力弹簧架螺钉	SCREW 11/64-40 L=11	1	1	
16	423.10-16	送料牙螺钉	SCREW 1/8-40 L=7	2	2	
17	423.10-17	牙架销螺钉	SCREW 3/16-28 L=9	2	2	
18	423.10-18	牙架曲柄螺钉	SCREW 3/16-28 L=14	2	2	
19	423.10-19	牙架螺钉	SCREW 3/16-28 L=14	1	1	
20	423.10-20	抬牙偏心销卡簧	E-RING 3	1	1	
21	423.10-21	送料传动摇杆滑块销	PIN	1	1	
22	423.10-22	挡圈	THRUST COLLAR ASM D=11.11, W=10	1	1	
23	423.10-23	挡圈螺钉	SCREW 1/4-40 L=7	1	1	
24	423.10-24	送料偏心凸轮螺钉	SCREW 1/4-40 L=8	2	2	
25	423.10-25	凸轮连杆盖螺钉	SCREW 1/8-44 L=6.4	2	2	
26	423.10-26	连杆螺钉	HINGE SCREW D=9 H=7	2	2	
27	423.10-27	连杆螺母	NUT 9/32-28	2	2	
28	423.10-28	送料轴曲柄螺钉	SCREW 3/16-28 L=15.5	1	1	
29	423.10-29	挡板螺钉	SCREW 11/64-40 L=8.5	4	4	
30	423.10-30	摇杆限位板螺钉	SCREW 1/64-40 L=7	1	1	
31	423.10-31	平衡重量组件螺钉	SCREW	2	2	
32	423.10-32	送料轴	FEED ROCKER SHAFT	1	1	
33	423.10-33	送料轴前套	BUSHING_FRONT	1	1	
34	423.10-34	送料轴后套	FEED ROCKER SHAFT BUSHING_FRO	1	1	
35	423.10-35	送料偏心凸轮	ECENTRIC CAM	1	1	
36	423.10-36	凸轮连杆	ROD	1	1	
37	423.10-37	送料凸轮连杆盖板	SIDE DISC PLATE	1	1	
38	423.10-38	滚针轴承	BEARING	1	1	
39	423.10-39	送料限位板	REVERSE FEED LIMITER	1	1	
40	423.10-40	送料限位板螺钉	SCREW 11/64-40 L=11	1	1	
41	423.10-41	拉簧	TENSION SPRING RACK	1	1	
42	423.10-42	送料可变曲柄螺钉	SCREW 3/16-28 L=14	1	1	
43	423.10-43	偏心凸轮连杆	CONNECTING ROD	1	1	
44	423.10-44	送料轴曲柄	FEED ROCKER SHAFT CRANK	1	1	
45	423.10-45	送料传动摇杆	FEED DRIVING ROCKER	1	1	
46	423.10-46	挡板 A	PLATE A	1	1	
47	423.10-47	摇杆限位板	STOPPER PLATE	1	1	
48	423.10-48	挡板 B	PLATE B	1	1	
49	423.10-49	送料可变轴	FEED VARIABLE SHAFT	1	1	
50	423.10-50	送料可变轴套	BUSHING_FRONT	1	1	
51	423.10-51	送料可变曲柄	FEED VARIABLE ARM C	1	1	
52	423.10-52	送料传动摇杆滑块	FEED DRIVING ROCKER BLOCK	2	2	

11. 下轴勾线部件

HOOK DRIVING SHAFT & HOOK COMPONENTS

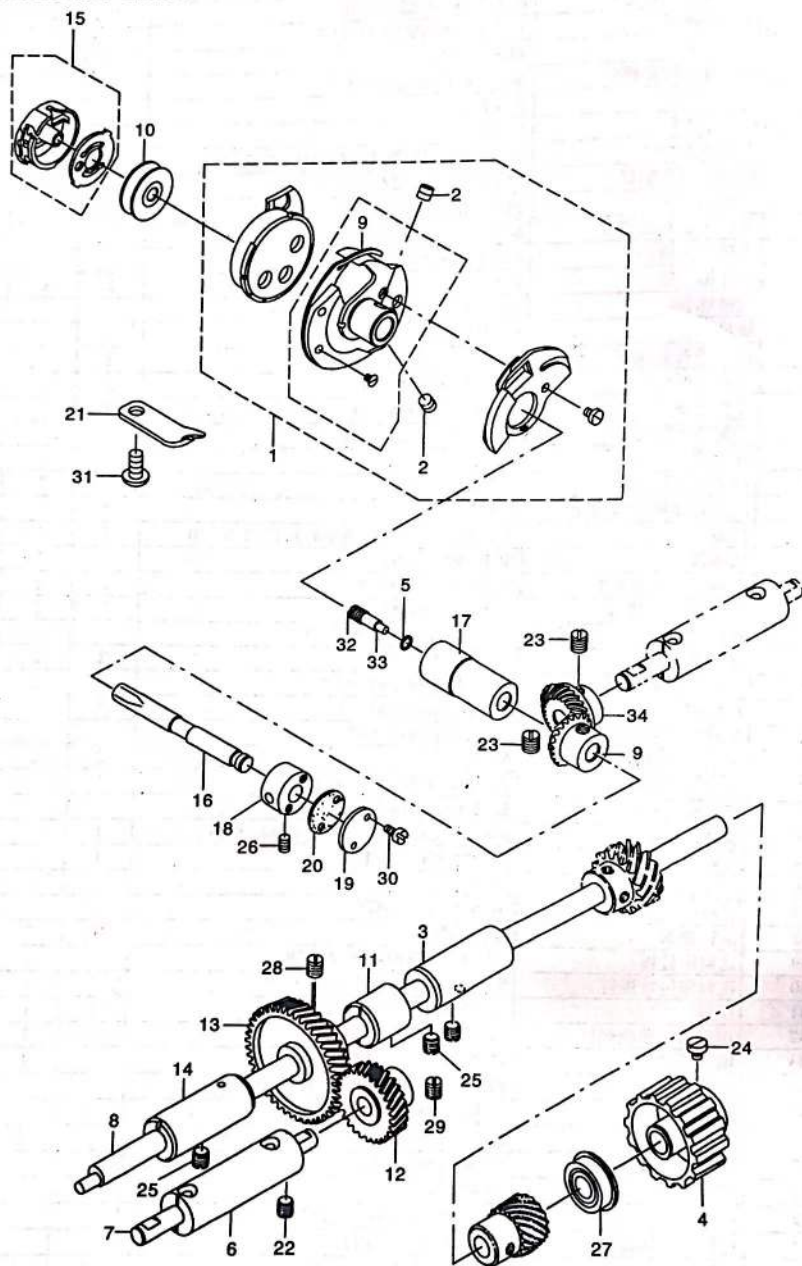

11.下轴勾线部件

11.HOOK DRIVING SHAFT & HOOK COMPONENTS

序号	图号	名称	DESCRIPTION	2284	2284-7	备注
1	423.11-01	旋梭组件	HOOK COMPL,RIGHT	1	1	
2	423.11-01-01	旋梭螺钉	SCREW 11/64-40 L=4.5	(2)	(2)	
3	423.11-02	下轴后轴套	BUSHING REAR	1	1	
4	423.11-03	下轴同步轮	HOOK DRIVING SHAFT SPROCKET	1	1	
5	423.11-04	橡皮圈	RUBBER RING	1	1	
6	423.11-05	旋梭驱动轴套	BUSHING	1	1	
7	423.11-06	旋梭驱动轴	SHAFT	1	1	
8	423.11-07	下轴	HOOK DRIVNG SHAFT	1	1	
9	423.11-08	旋梭伞齿轮	PINION ASM.	1	1	
10	423.11-09	梭心	BOBBIN S	1	1	
11	423.11-10	下轴中轴套	BUSHING ,INTERMEDIATE	1	1	
12	423.11-11	驱动轴斜齿轮	HELICAL GEAR B	1	1	
13	423.11-12	下轴斜齿轮	HELICAL GEAR A ,A	1	1	
14	423.11-13	下轴前轴套	BUSHING ,FRONT	1	1	
15	423.11-14	梭心套组件	BOBBIN CASE ASM.	1	1	
16	423.11-15	旋梭轴	HOOK SHAFT	1	1	
17	423.11-16	旋梭后轴套	HOOK SHAFT BUSHING	1	1	
18	423.11-17	旋梭前轴套	HOOK SHAFT BUSHING	1	1	
19	423.11-18	旋梭轴套盖	BUSHING CAP	1	1	
20	423.11-19	轴套盖密封垫	GASKET	1	1	
21	423.11-20	旋梭定位勾	INNER HOOK STOPPER	1	1	
22	423.11-21	旋梭驱动轴套螺钉	SCREW 15/64-28 L=7	1	1	
23	423.11-22	齿轮螺钉	SCREW 1/4-40 L=8	4	4	
24	423.11-23	同步轮螺钉	SCREW 1/4-40 L=7	2	2	
25	423.11-24	下轴前轴套螺钉	SCREW 15/64-28 L=7	3	3	
26	423.11-25	旋梭轴轴套螺钉	SCREW 15/64-28 L=8	1	1	
27	423.11-26	轴承	BEARING D=9.52X22.22	1	1	
28	423.11-27	齿轮螺钉	SCREW 1/4-40 L=8	2	2	
29	423.11-28	齿轮螺钉	SCREW 1/4-40 L=8	2	2	
30	423.11-29	轴套盖螺钉	SCREW 1/8-44L=8	2	2	
31	423.11-30	定位勾螺钉	SCREW 11/64-40 L=9	1	1	
32	423.11-31	旋梭油量调节螺钉	OIL SEAL SCREW	1	1	
33	423.11-32	油芯	OIL WICK	1	1	
34	423.11-33	旋梭驱动伞齿轮	GEAR ASM.LARGE	1	1	

12. 润滑部件

LUBRICATION COMPONENTS

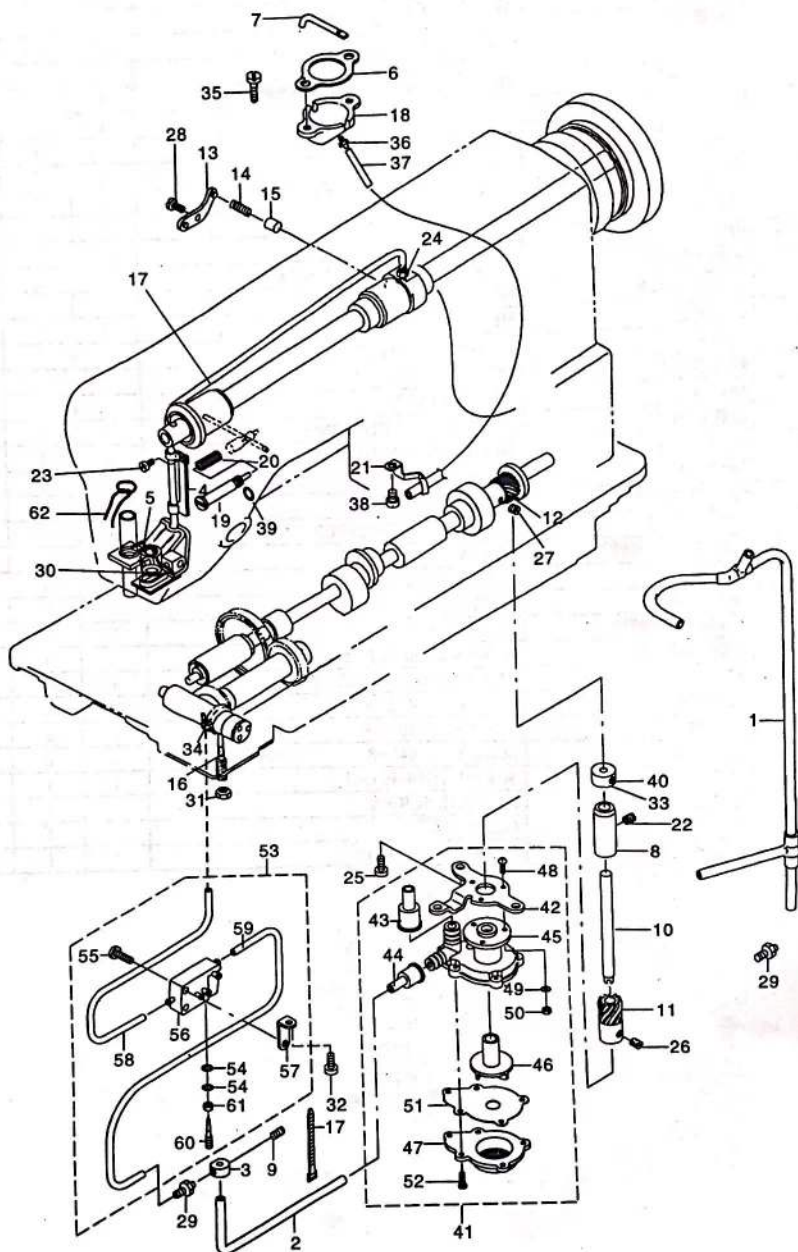

12. 润滑部件

12. LUBRICATION COMPONENTS

序号	图号	名称	DESCRIPTION	2284	2284-7	备注
1	423.12-01	上轴共油管组件	OIL SUPPLY PIPE ASM.	1	1	
2	423.12-02	下轴供油管	OIL SUPPLY PIPE	1	1	
3	423.12-03	分配器	DISTRIBUTOR	1	1	
4	423.12-04	油管夹	FELT ASM.	1	1	
5	423.12-05	压毡簧	FELT PRESSER	1	1	
6	423.12-06	密封垫	GASKET	1	1	
7	423.12-07	示油窗供油管	OIL TUBE	1	1	
8	423.12-08	竖轴套筒	BUSHING	1	1	
9	423.12-09	螺钉	SCREW 11/64-40 L=5	1	1	
10	423.12-10	竖轴	UPRIGHT SHAFT	1	1	
11	423.12-11	油泵齿轮	PUMP DRIVING GEAR	1	1	
12	423.12-12	下轴油泵齿轮	PUMP DRIVING GEAR A	1	1	
13	423.12-13	柱塞压板	PLUNGER THREST PLATE	1	1	
14	423.12-14	柱塞弹簧	PLUNGER SPRING	1	1	
15	423.12-15	柱塞	PLUNGER	1	1	
16	423.12-16	油量调节螺钉	OIL REGULATING SCREW	1	1	
17	423.12-17	电线扎带	CABLE BAND	1	1	
18	423.12-18	油箱	OIL TANK	1	1	
19	423.12-19	油量调节销	OIL TEGULATING SCREW	1	1	
20	423.12-20	油量销弹簧	SPRING	1	1	
21	423.12-21	油管导向板	OIL FELT GUIDE	1	1	
22	423.12-22	竖轴套筒螺钉	SCREW 15/64-40 L=7	1	1	
23	423.12-23	油管夹螺钉	SCREW 11/64-40 L=7	1	1	
24	423.12-24	吸油管连接螺钉	CONNECTING SCREW	1	1	
25	423.12-25	油泵底座螺钉	SCREW 11/64-40 L=11	2	2	
26	423.12-26	油泵齿轮螺钉	SCREW 1/4-40 L=4.5	2	2	
27	423.12-27	下轴油泵齿轮螺钉	SCREW 1/4-40 L=4.5	2	2	
28	423.12-28	柱塞压板螺钉	SCREW 11/64-40 L=7	1	1	
29	423.12-29	分配器连接螺钉	CONNECTING SCREW	2	2	
30	423.12-30	吸油毡	OIL WICK	0.2	0.2	
31	423.12-31	螺母	NUT 15/64-28	1	1	
32	423.12-32	调油座螺钉	SCREW 11/64-40 L=5	1	1	
33	423.12-33	挡圈螺钉	SCREW	2	2	
34	423.12-34	旋梭轴供油管连接螺钉	CONNECTING SCREW	1	1	
35	423.12-35	油箱座螺钉	SCREW 11/64-40 L=14	2	2	
36	423.12-36	油管连接螺钉	CONNECTING SCREW	1	1	
37	423.12-37	油管	OIL TUBE	0.3	0.3	
38	423.12-38	导向板螺钉	SCREW 11/64-40 L=5	1	1	
39	423.12-39	O型圈	RUBBER RING	1	1	
40	423.12-40	挡圈	THRUST COLLAR ASM.	1	1	
41	423.12-41	油泵组件	LUBRICATING OIL PUMP ASM.	1	1	
42	423.12-41-01	油泵底座	OIL PUMP INSTALING BASE	(1)	(1)	
43	423.12-41-02	油管橡皮接头	RUBBER JOINT	(1)	(1)	
44	423.12-41-03	油管橡皮接头	RUBBER JOINT	(1)	(1)	
45	423.12-41-04	润滑油管泵	LUBRICATING OIL PUMP	(1)	(1)	
46	423.12-41-05	油泵进油器	OIL PUMP IMPELLER	(1)	(1)	
47	423.12-41-06	油泵盖底	OIL PUMP IMPELLER COVER	(1)	(1)	
48	423.12-41-07	油泵盖底螺钉	SCREW M3X0.5 L=10	(3)	(3)	
49	423.12-41-08	垫圈	WASHER	(3)	(3)	
50	423.12-41-09	螺母	NUT M3X0.5	(3)	(3)	
51	423.12-41-10	油泵盖	LUBRICATING OIL PUMP COVER	(3)	(3)	
52	423.12-41-11	螺钉	SCREW	(5)	(5)	
53	423.12-42	调油座阀组件	OIL REGULATING VALVE ASM.	1	1	
5	423.12-42-01	垫圈	WASHER	(2)	(2)	
55	423.12-42-02	连接板螺钉	SCREW 11/64-40 L=14	(1)	(1)	
56	423.12-42-03	调油座	OIL REGULATING VALVE	(1)	(1)	
57	423.12-42-04	调油座连接板	WIPER LINK JOINT	(1)	(1)	
58	423.12-42-05	油管	OIL TUBE	(0.18)	(0.18)	
59	423.12-42-06	油管	OIL TUBE	(0.14)	(0.14)	
60	423.12-42-07	调油螺钉	OIL ADJUSTING SCREW	(1)	(1)	
61	423.12-42-08	螺母	NUT 11/64-40	(1)	(1)	
62	423.12-43	油线	OIL WICK	0.2	0.2	
63	423.12-44	吸油管	OILTUBE	1	1	

13. 线架部件

THREAD STAND COMPONENTS

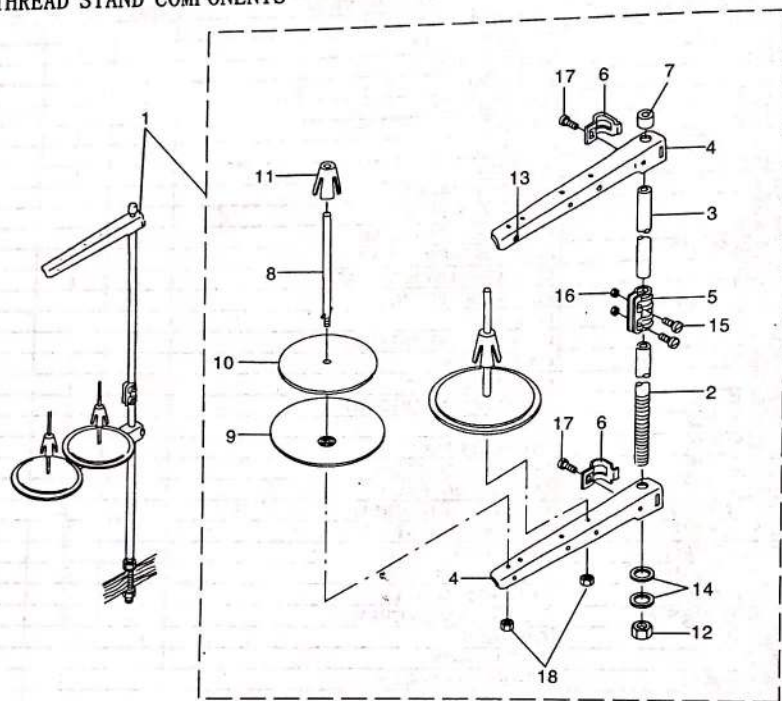

13. 线架部件

13. THREAD STAND COMPONENTS

序号	图号	名称	DESCRIPTION	2284	2284-7	备注
1	423.13-01	线架组件	THREAD STAND ASM.	(1)	(1)	
2	423.13-01-01	线架下杆	SPOOL REST ROD, LOWER	(1)	(1)	
3	423.13-01-02	线架上杆	SPOOL REST ROD, UPPER	(1)	(1)	
4	423.13-01-03	线架臂	THREAD GUIDE ARM B	(2)	(2)	
5	423.13-01-04	上下杆接头	SPOOL REST ROD JOINT	(1)	(1)	
6	423.13-01-05	线架臂接头	THREAD GUIDE ARM JOINT	(2)	(2)	
7	423.13-01-06	线架杆帽	SPOOL REST ROD CAP	(1)	(1)	
8	423.13-01-07	线盘钉	SPOOL PIN	(2)	(2)	
9	423.13-01-08	线盘	SPOOL REST	(2)	(2)	
10	423.13-01-09	线盘垫	SPOOL REST CUSHION	(2)	(2)	
11	423.13-01-10	线盘固定架	SPOOL RETAINER	(2)	(2)	
12	423.13-01-11	螺母	NUT	(1)	(1)	
13	423.13-01-12	导线塞	THREAD GUIDE	(2)	(2)	
14	423.13-01-13	垫圈	WASHER 16X30X2.6	(2)	(2)	
15	423.13-01-14	螺钉	SCREW M5 L=14	(2)	(2)	
16	423.13-01-15	螺母	NUT M5	(2)	(2)	
17	423.13-01-16	螺钉	SCREW M6 L=16	(2)	(2)	
18	423.13-01-17	螺母	NUT M5	(2)	(2)	

14. 油盘、膝控部件

OIL RESERVOIR & KNEE LIFTER COMPONENTS

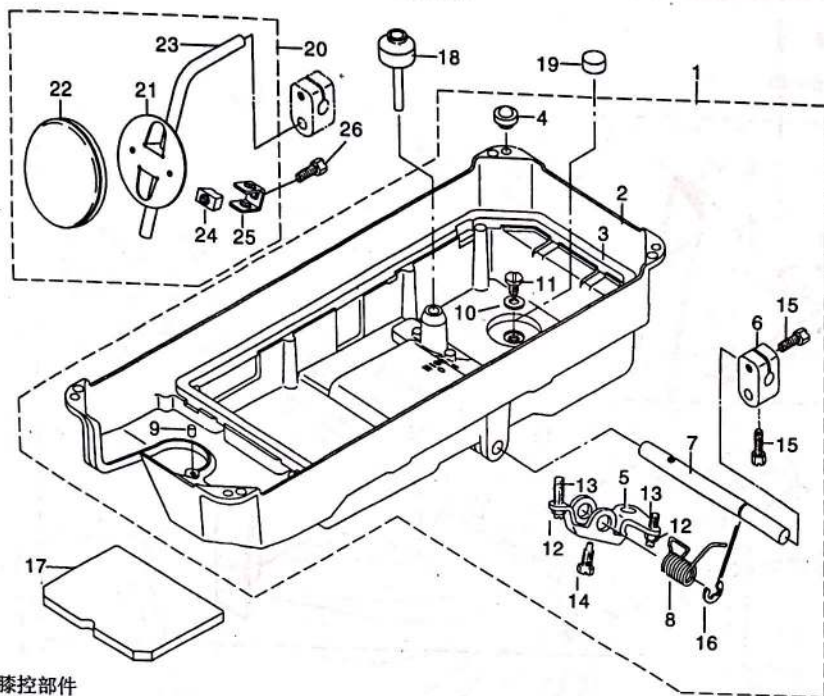

14. 油盘、膝控部件

14. OIL RESERVOIR & KNEE LIFTER COMPONENTS

序号	图号	名称	DESCRIPTION	2284	2284-7	备注
1	423.14-01	油盘组件	OIL RESERVOIR ASM.	1	1	
2	423.14-01-01	油盘	OIL RESERVOIR	(1)	(1)	
3	423.14-01-02	油盘密封垫	OIL RESERVOIR GASKET	(1)	(1)	
4	423.14-01-03	垫块	RUBBER CUSHION	4	4	
5	423.14-01-04	抬压脚双向曲柄	CONNECTING ROT,VERTICAL	(1)	(1)	
6	423.14-01-05	抬压脚操纵接头	BRACKET	(1)	(1)	
7	423.14-01-06	膝提压脚轴	KNEE PRESS ROD	(1)	(1)	
8	423.14-01-07	弹簧	SPRING	(1)	(1)	
9	423.14-01-08	橡胶塞	RUBBER PLUG	(1)	(1)	
10	423.14-01-09	O型圈	RUBBER RING	(1)	(1)	
11	423.14-01-10	油盘放油螺钉	SCREW	(1)	(1)	
12	423.14-01-11	螺母	NUT M6	(1)	(1)	
13	423.14-01-12	螺栓	SCREW M6 L=30	(2)	(2)	
14	423.14-01-13	抬压脚双向曲柄螺钉	SCREW M6 L=17.5	(2)	(2)	
15	423.14-01-14	操纵杆接头螺钉	SCREW M6 L=20	1	1	
16	423.14-01-15	卡簧	E-RING 10	(2)	(2)	
17	423.14-02	油盘海绵擦	OIL RESERVOIR BASE	(1)	(1)	
18	423.14-03	压脚顶杆	KNEE PRESS LIFTER ROD	1	1	
19	423.14-04	磁铁	OIL RESERVOIR MAGNET	1	1	
20	423.14-05	操纵板组件	KNEE PRESS PLATE ASM.	1	1	
21	423.14-05-01	操纵板	KNEE PRESS PLATE	1	1	
22	423.14-05-02	操纵板软垫	KNEE PRESS PLATE COVER	(1)	(1)	
23	423.14-05-03	操纵杆	KNEE LIFTER PLATE ROD	(1)	(1)	
24	423.14-05-04	操纵杆垫块	RUBBER	(1)	(1)	
25	423.14-05-05	操纵杆夹头	KNEE PRESS PLATE HOLDER	(1)	(1)	
26	423.14-05-06	操纵杆夹头螺钉	SCREW	(1)	(1)	

15. 带轮罩部件

BELT COVER COMPONENTS (15)

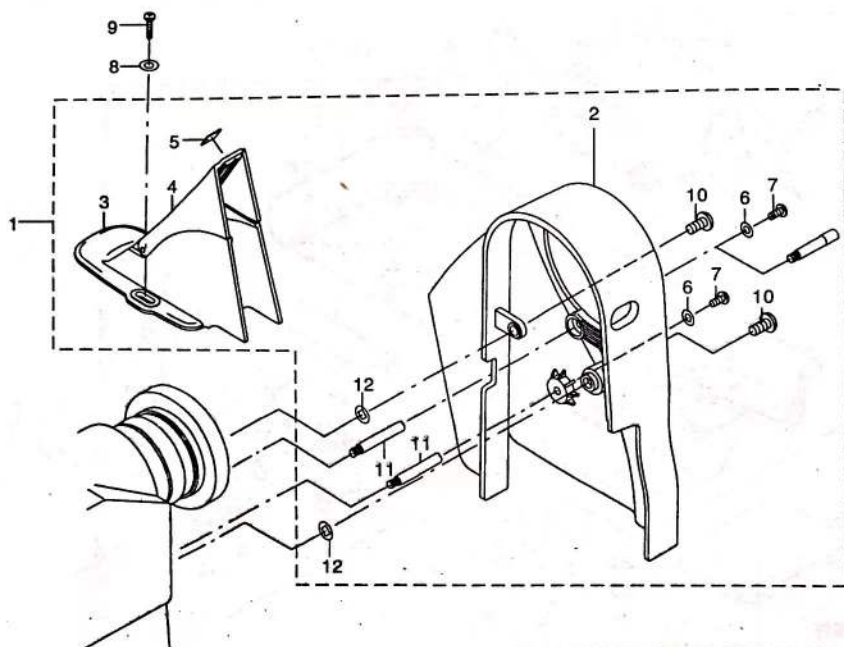

15.带轮罩部件

15.BELT COVER COMPONENTS

序号	图号	名称	DESCRIPTION	2284	2284-7	备注
1	423.15-01	带轮罩组件	BELT COVER ASM.	1	1	
2	423.15-01-01	上轮前罩壳	BELT COVER A	(1)	(1)	
3	423.15-01-02	上轮后罩壳(B)	BELT COVER B	(1)	(1)	
4	423.15-01-03	上轮后罩壳(C)	BELT COVER C	(1)	(1)	
5	423.15-01-04	橡胶粘贴板	VOBROISOLATING RUBBER	(1)	(1)	
6	423.15-01-05	垫圈	AWSHER 4.5X10X0.8	(2)	(2)	
7	423.15-01-06	支柱螺钉	SCREW 11/64-40 L=9	(2)	(2)	
8	423.15-01-07	垫圈	WASHER 4.5X10X0.8	(2)	(2)	
9	423.15-01-08	木螺钉	WOOD SCREW D=4.1,L=20	(2)	(2)	
10	423.15-01-09	前罩壳固定螺钉	SCREW 15/64-28 L=12	(2)	(2)	
11	423.15-01-10	前罩壳支柱	BELT COVER SUPPORT STUD	(2)	(2)	
12	423.15-01-11	垫圈	WASHER	(2)	(2)	

16. 附件部件

ACCESSORIES COMPONENTS

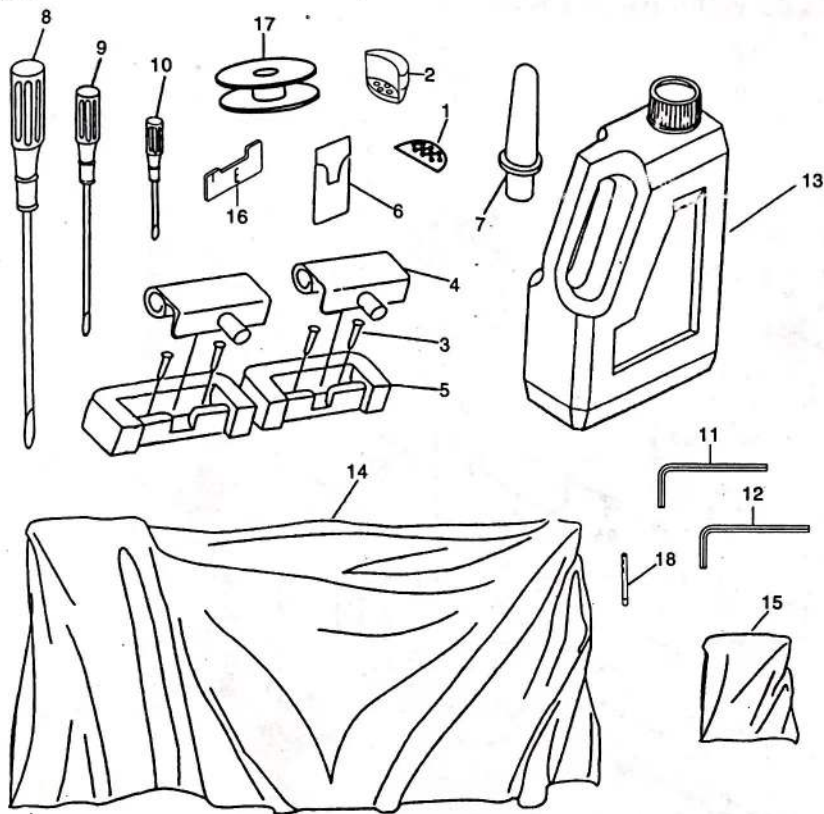

16. 附件部件

16.ACCESSORIES COMPONENTS

序号	图号	名称	DESCRIPTION	2284	2284-7	备注
1	423.16-01	油盘座垫	OIL RESER VOIR FELT CUSHION	2	2	
2	423.16-02	油盘支座	OIL RESRRVOIR RUBBER CUSHION	2	2	
3	423.16-03	铜钉	NAIL	12	12	
4	423.16-04	机头连接勾	MACHINE HINGE	2	2	
5	423.16-05	机头连接座	MACHINE HINGE PLATE	2	2	
6	423.04-44	机针	NEEDLE	3	3	
7	423.16-06	机头支柱	MACHINE REST IN	1	1	
8	423.16-07	螺丝刀(大)	SCREWDRIVER LARGE	1	1	
9	423.16-08	螺丝刀(中)	SCREWDRIVER MEDIUM	1	1	
10	423.16-08	螺丝刀(小)	SCREWDRIVER SMALL	1	1	
11	423.16-10	内六角扳手2.5	HEXAGON WRENCH 2.5	1	1	
12	423.16-11	内六角扳手2	HEXAGON WRENCH 2	1	1	
13	423.16-12	大油壶	OIL RESERVOIR ASM	1	1	
14	423.16-13	机头罩	MACHINE HEAD COVER	1	1	
15	423.16-14	汽泡袋	PACKET	10	10	
16	423.07-19	同步板	TIMING GAUGE E	1	1	
17	423.11-09	梭心	BOBBIN S	2	2	
18	423.01-13	导线柱	THREAD GUIDE PIN	1	1	

17、剪线电磁铁部件

THREAD TRIMMER MECHANISM COMPONENTS

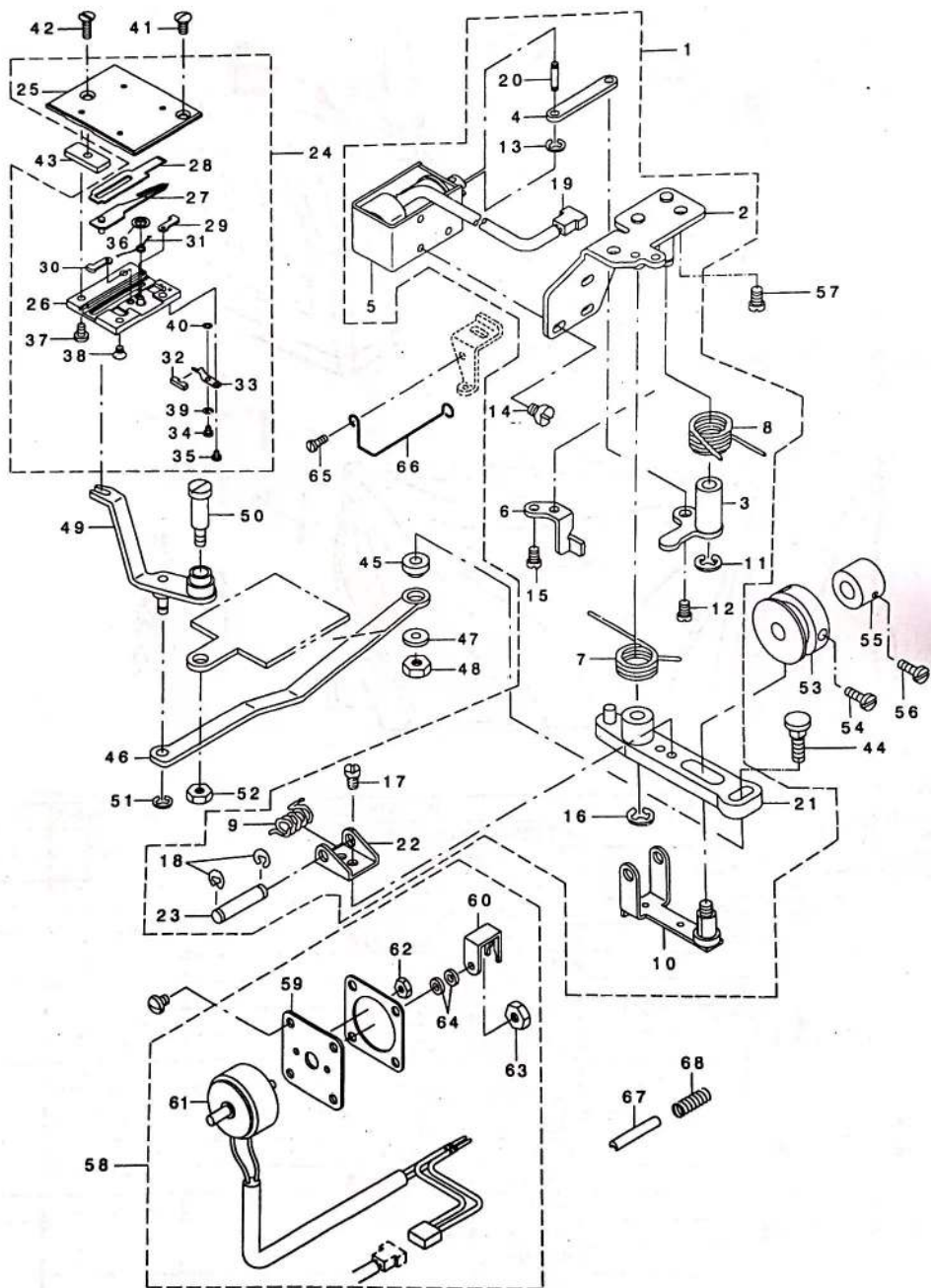

17、剪线电磁铁部件THREAD TRIMMER MECHANISM COMPONENTS

序号	图号	名称	DESCRIPTION	2284	2284-7	备注
1	424.17-01	剪线器传动组件	THREAD TRIMMER DRIVING UNIT		1	
2	424.17-01-01	支承盘组件	BASE PLATE ASM		1	
3	424.17-01-02	离合器组件	CLUTCH PLATE ASM		1	
4	424.17-01-03	离合器连杆	CLUTCH LINK		1	
5	424.17-01-04	剪线电磁铁	MAGNET		1	
6	424.17-01-05	传动臂限位器	DRIVING ARM STOPPER		1	
7	424.17-01-06	回刀弹簧	KNIFE RETURN SPRING		1	
8	424.17-01-07	离合器弹簧	SLUTCH SPRING		1	
9	424.17-01-08	滚轮柱复位弹簧	ROLLER RETURN SPRING		1	
10	424.17-01-09	滚轮柱摇臂	ROLLER ASM ASM		1	
11	424.17-01-10	卡簧	E-RING 6		1	
12	424.17-01-11	螺钉	HINGE SKEW D=6 H=2.9		1	
13	424.17-01-12	卡簧	E-RING 2.5		2	
14	424.17-01-13	螺钉	SCREW M4 L=6		3	
15	424.17-01-14	螺钉	SCREW 11/64-40 L=9		2	
16	424.17-01-15	卡簧	E-RING 6		1	
17	424.17-01-16	螺钉	SCREW 9/64-40 L=6		1	
18	424.17-01-17	卡簧	E-RING 4		1	
19	424.17-01-18	接线头	HOUSING 2P		1	
20	424.17-01-19	连杆轴	WIPER LINK SHAFT, A		1	
21	424.17-01-20	传动刀臂组件	KNIFE DRIVING ARM ASM		1	
22	424.17-01-21	可转刀臂架	ROLLER ARM BRACKET		1	
23	424.17-01-22	可转刀臂轴	ROLLER FULCRUM SHAFT		1	
24	424.17-02	切线刀组件	KNIFE UNIT		1	
25	424.17-02-01	滑板	SLIDING PLATE		(1)	
26	424.17-02-02	刀座	KNIFE BASE		(1)	
27	424.17-02-03	传动刀	DRIVING KNIFE ASM		(1)	
28	424.17-02-04	定刀	FIXED KNIFE		(1)	
29	424.17-02-05	刀塞(右)	KNIFE STOPPER, RIGHT		(1)	
30	424.17-02-06	刀塞(左)	KNIFE STOPPER, LEFT		(1)	
31	424.17-02-07	弹簧	SPRING		(1)	
32	424.17-02-08	毛毡	FELT		(1)	
33	424.17-02-09	油毡夹	CLAMP PLATE		(1)	
34	424.17-02-10	螺钉	SCREW 3/32-56 L=3		(1)	
35	424.17-02-11	螺钉	SCREW 3/32-56 L=3		(1)	
36	424.17-02-12	弹簧垫圈	LOCATING SPRING WASHER		(1)	
37	424.17-02-13	刀座螺钉	SCREW 9/64-40 L=6		(2)	
38	424.17-02-14	螺钉	SCREW 9/64-40 L=5		(2)	
39	424.17-02-15	垫圈	SPRING WASHER M2.6		(1)	
40	424.17-02-16	垫圈	WASHER B T=0.4		(1)	
41	424.17-03	螺钉	SCREW 11/64-40 L=8.5		1	
42	424.17-04	螺钉	SCREW 11/64-40 L=9.5		1	
43	424.17-05	固定板	FIXED PLATE		1	
44	424.17-06	活动刀铰链螺钉	MOVING KNIFE LINK PIN		1	
45	424.17-07	铰链螺套	MOVING KNIFE LINK BASE		1	
46	424.17-08	活动刀连杆	MOVING KNIFE LINK		1	
47	424.17-09	垫圈	WASHER		1	

17、剪线电磁铁部件

THREAD TRIMMER MECHANISM COMPONENTS

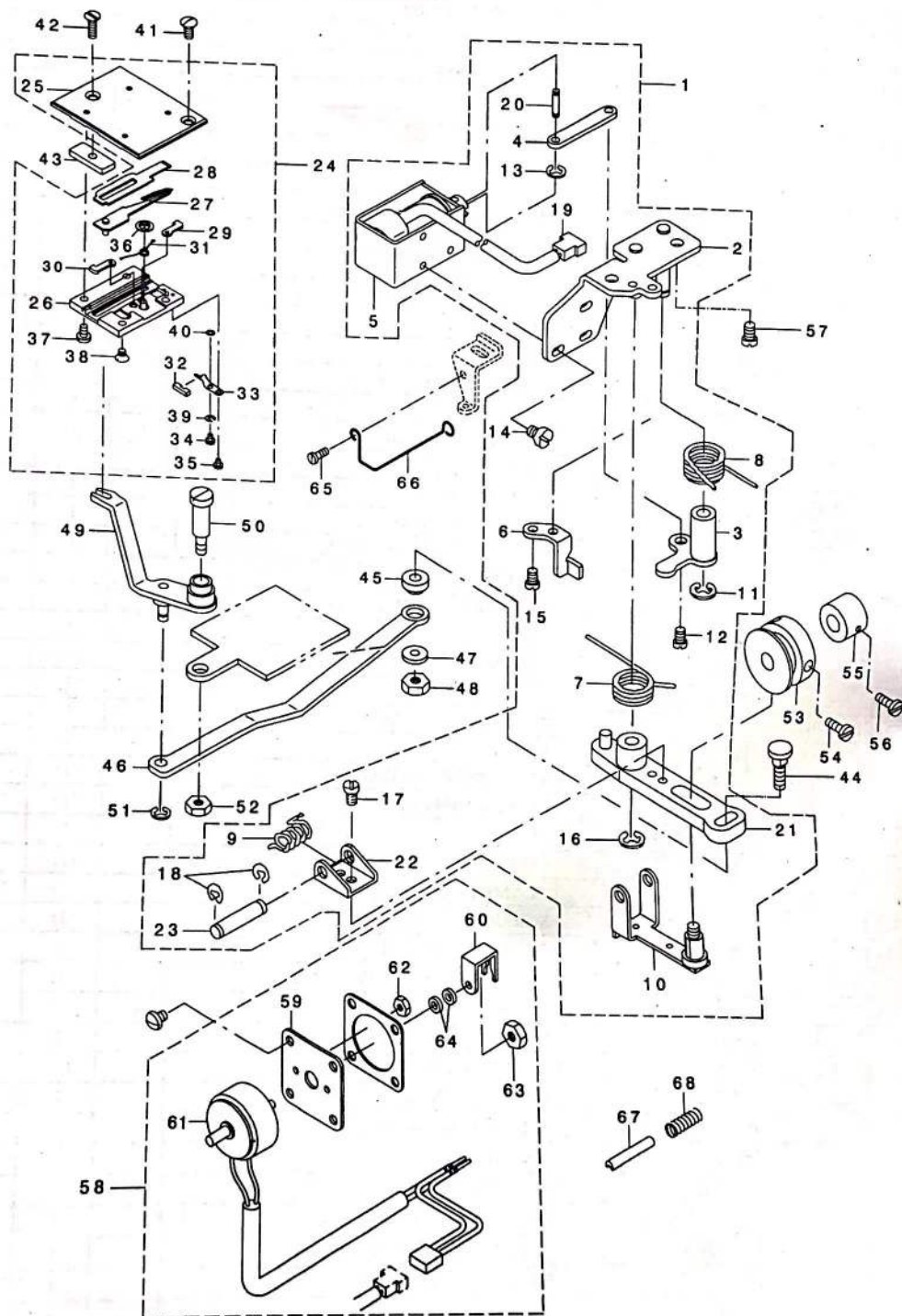

48	424.17-10	螺母	NUT 15/64-28			
49	424.17-11	叉形连杆	FORK KNIFE ASM		1	备注
50	424.17-12	铰链螺钉	HINGE SCREW D=7.94 H=15		1	
51	424.17-13	卡簧	E-RING		1	
52	424.17-14	螺母	NUT 15/64-28		1	
53	424.17-15	切线凸轮	THREAD CUTTING CAM B		1	
54	424.17-16	螺钉	SCREW 1/4-40 L=7		1	
55	424.17-17	挡圈	THRUST COLLAR ASMD=9.53 W=10		2	
56	424.17-18	螺钉	SCREW 15/64-28 L=7		1	
57	424.17-19	支承盘螺钉	SCREW 15/64-28 L=9		2	
58	424.17-20	松线电磁吸铁组件	SOLENOID ASM		2	
59	424.17-20-01	吸铁底座	SOLENOID FITTING BASE		1	
60	424.17-20-02	松线推盘	THREAD RELEASE PUSH PLATE		(1)	
61	424.17-20-03	松线电磁铁	THREAD RELEASE SOLENOID ASM		(1)	
62	424.17-20-04	螺母	NUT M3		(1)	
63	424.17-20-05	螺母	NUT M4×0.7		(2)	
64	424.17-20-07	防振橡胶垫	FRAME SIDE COVER GASKET		(1)	
65	424.17-22	螺钉	SCREW 11/64-40 L=5		1	
66	424.17-23	电线固定簧	CORD PRESSER		1	
67	424.17-24	弹簧销	SPRING PIN 3×18		1	
68	424.17-25	弹簧	SPRING		1	

18、挑线电磁铁部件

UPPER THREAD FEEDER COMPONENTS

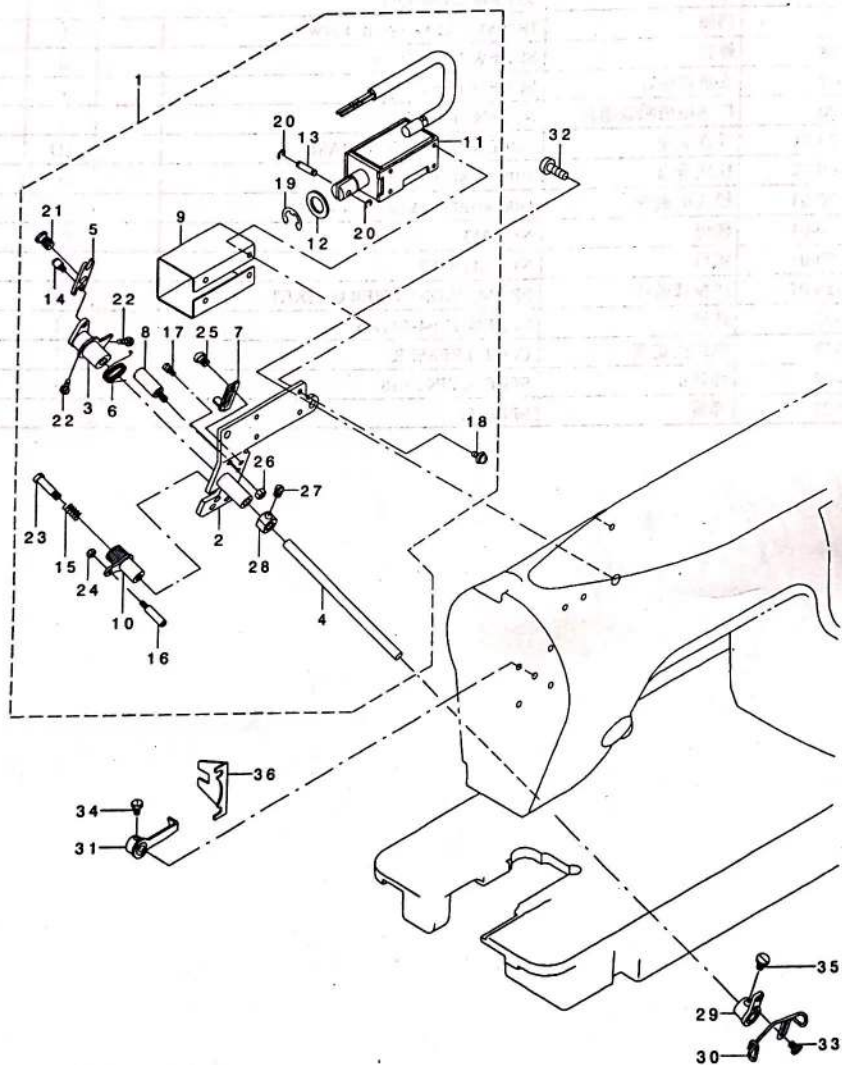

18、挑线电磁铁部件UPPER THREAD FEEDER COMPONENTS

序号	图号	名称	DESCRIPTION	2284	2284-7	备注
1	424.18-01	挑线电磁铁组件	THREAD FEEDER ASM		1	
2	424.18-01-01	挑线底座组件	FITTING BASE COMPL		(1)	
3	424.18-01-02	挑线杠杆组件	FEED LEVER COMPL		(1)	
4	424.18-01-03	挑线杠杆轴	FEED LEVER SHAFT		(1)	
5	424.18-01-04	双叉口铰链	LINK		(1)	
6	424.18-01-05	挑线杠杆弹簧	FEED LEVER SPRING		(1)	
7	424.18-01-06	限位器	STOPPER		(1)	
8	424.18-01-07	销轴	SHAFT		(1)	
9	424.18-01-08	电磁铁盖	SOLENOID COVER		(1)	
10	424.18-01-09	限位板	PLATE		(1)	
11	424.18-01-10	电磁铁组件	SOLENOID COMPL		(1)	
12	424.18-01-11	限位橡胶垫	SOLENOID RUBBER		(1)	
13	424.18-01-12	叉口连接销	PLUNGER CONNECTING PIN		(1)	
14	424.18-01-13	叉口摆动销	BUTTON CLAMP STOP PIN		(1)	
15	424.18-01-14	限位弹簧	SPRING		(1)	
16	424.18-01-15	挑线螺丝销	THREAD RELEASING SCREW STUD		(1)	
17	424.18-01-16	限位螺丝	SUSPENSION SCREW		(1)	
18	424.18-01-17	螺钉	SCREW M3 L=8		4	
19	424.18-01-18	卡簧	E-RING 9		(1)	
20	424.18-01-19	卡簧	E-RING 3		(2)	
21	424.18-01-20	铰链螺丝	HINGE SCREW D=6.35 H=2.4		(1)	
22	424.18-01-21	螺丝	SCREW 11/64-40 L=5		(2)	
23	424.18-01-22	铰链螺丝	HIGE SCREW D=4.80 H=14.5		(1)	
24	424.18-01-23	螺母	NUT 1/8-44		(1)	
25	424.18-01-24	螺丝	SCREW 3/16-28 L=6		(1)	
26	424.18-01-25	螺母	NUT 3/16-28		(1)	
27	424.18-01-26	螺丝	SCREW 11/64-40 L=5		(2)	
28	424.18-01-27	挡圈	THRUST COLLAR K=6.35 W=8		(1)	
29	424.18-02	挑线挑线盘组件	FITTING PLATE COMPL		1	
30	424.18-03	挑线	WIRE		1	
31	424.18-04	限位器组件	STOPPER PLATE COMPL		1	
32	424.18-05	螺钉	SCREW 3/16-28 L=9		(2)	
33	424.18-06	螺钉	SCREW 9/64-40 L=5.0		2	
34	424.18-07	螺钉	SCREW 9/64-40 L=5.5		2	
35	424.18-08	螺钉	SCREW 9/64-40 L=5.5		2	
36	424.18-09	限位器导向板	STOPPER PLATE GUIDE		1	

19、倒缝电磁铁部件

AUTOMATIC REVERSE FEED MECHANISM COMPONENTS

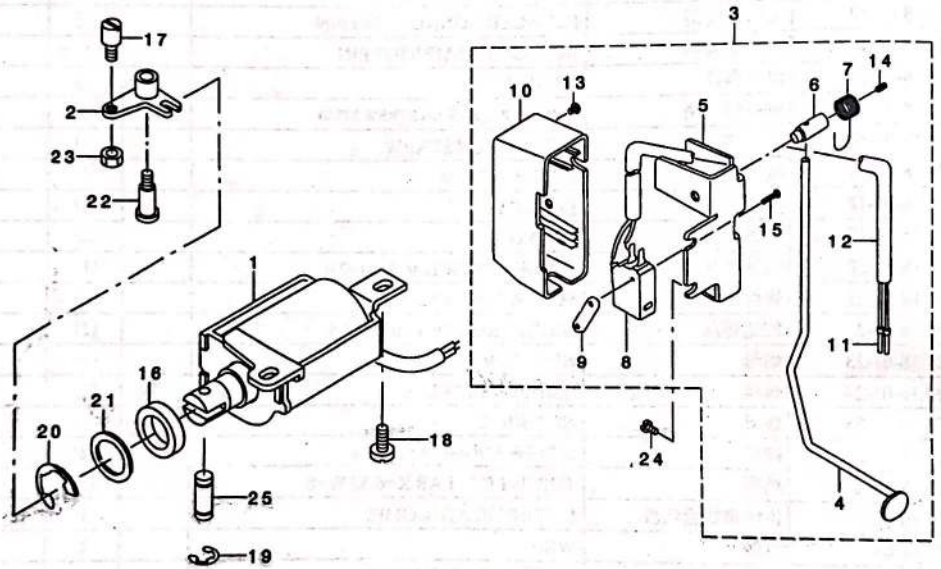

19、倒缝电磁铁部件 AUTOMATIC REVERSE FEED MECHANISM COMPONENTS

序号	图号	名称	DESCRIPTION	2284	2284-7	备注
1	424.19-01	倒缝电磁铁组件	MAGNET ASM		1	
2	424.19-02	倒缝电磁铁连接曲柄	REVERSE FEED MAGNET LINK		1	
3	424.19-03	倒缝开关组件	REVERSE FEED SWITCH		1	
4	424.19-03-01	倒缝开关杆	REVERSE FEED SWITCH LEVER		(1)	
5	424.19-03-02	倒缝开关底座	REVERSE FEED SWITCH BASE		(1)	
6	424.19-03-03	倒缝开关轴	REVERSE FEED SWITCH SHAFT		(1)	
7	424.19-03-04	倒缝开关弹簧	REVERSE FEED SWITCH SPRING		(1)	
8	424.19-03-05	小开关	MICRO SWITCH		(1)	
9	424.19-03-06	小开关固定板	MICRO SWITCH PLATE		(1)	
10	424.19-03-07	倒缝送料开关盖	REVERSE FEED SWITCH COVER		(1)	
11	424.19-03-08	接线头	PIN CONTACT		(2)	
12	424.19-03-09	电线	2-CORE CABTYRE CORD		(1.5)	
13	424.19-03-10	螺丝	SCREW M4 L=6		(1)	
14	424.19-03-11	螺丝	SCREW M4×8		(1)	
15	424.19-03-12	螺丝	SCREW M3 L=15		(2)	
16	424.19-04	橡皮垫圈	RUBBER PLUBGER		1	
17	424.19-05	限位连接螺钉	SCREW 15/64-28		1	
18	424.19-06	螺丝	SCREW 15/64-28 L=9		2	
19	424.19-07	卡簧	E-RING 4		2	
20	424.19-08	卡簧	E-RING 12		1	
21	424.19-09	垫圈	WASHER 16×24×2.6		1	
22	424.19-10	曲柄铰链螺钉	HINGE SCREW D=7.94 H=15		1	
23	424.19-11	螺母	NUT 15/64-28		1	
24	424.19-12	螺丝	SCREW 3/16-28 L=6		2	
25	424.19-13	磁铁连接销	PLUNGER ARM PIN		1	

20、扫线电磁铁部件

WIPER MECHANISM COMPONENTS

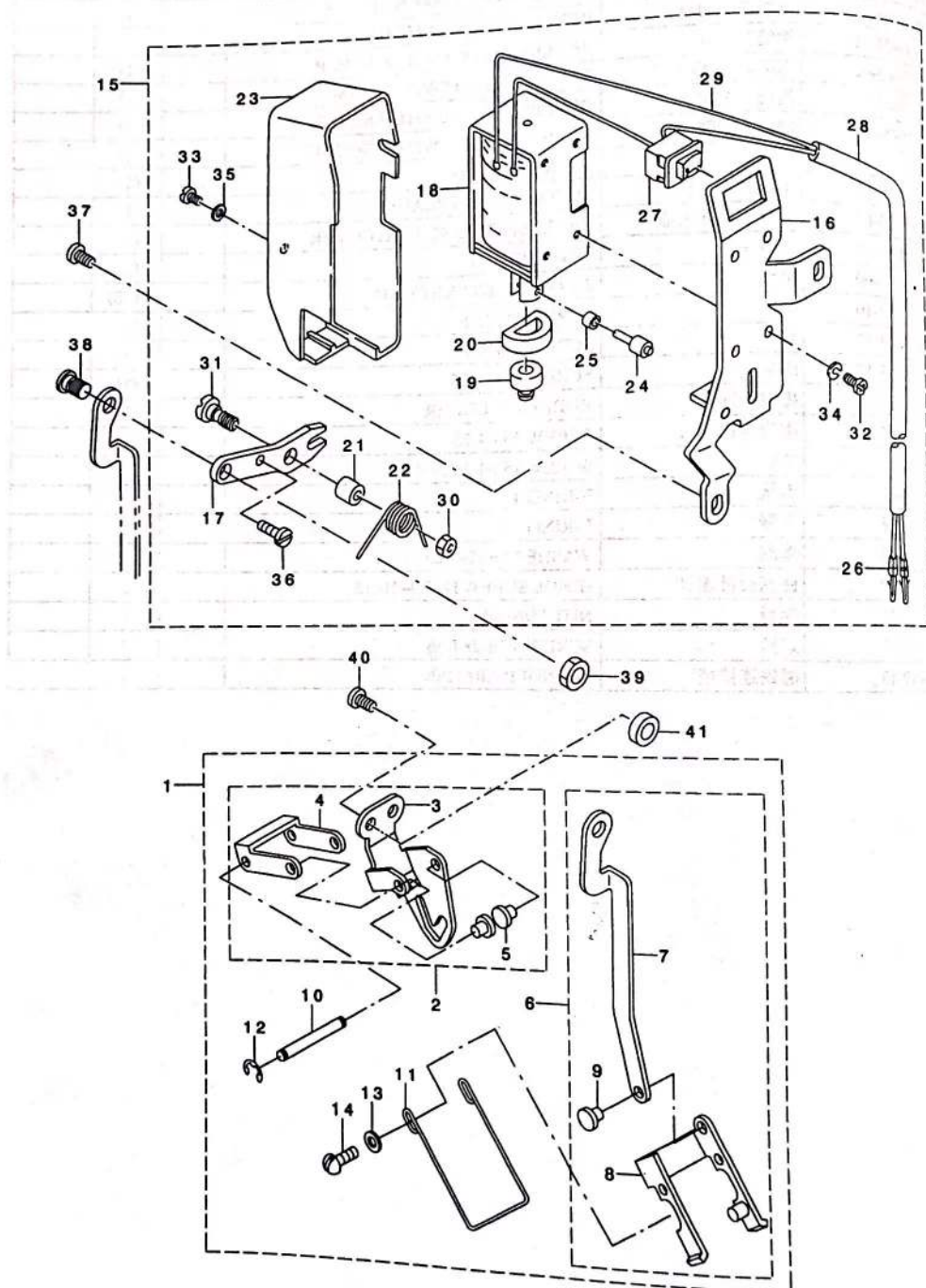

20、扫线电磁铁部件WIPER MECHANISM COMPONENTS

序号	图号	名称	DESCRIPTION	2284	2284-7	备注
1	424.20-01	扫线器组件	WIPER ASM		1	
2	424.20-01-01	扫线器底部组件	WIPER BASE ASM		(1)	
3	424.20-01-01-01	扫线器底座	WIPER BASE		(1)	
4	424.20-01-01-02	扫线器接头	WIPER LINK 1		(1)	
5	424.20-01-01-03	滑动销	PIN		(2)	
6	424.20-01-02	扫线器连杆组件	WIPER LINK COMPL		(1)	
7	424.20-01-02-01	扫线器连杆	WIPER LINK		(1)	
8	424.20-01-02-02	扫线架	WIPER LIND ASM 2		(1)	
9	424.20-01-02-03	滑动销	PIN		(1)	
10	424.20-03	扫线器接头销轴	WIPER LINK SHAFT		(1)	
11	424.20-04	扫线器	WIPER		(1)	
12	424.20-05	卡簧	E-RING 3.2		(2)	
13	424.20-06	垫圈	WASHER 3.7×8×1		(2)	
14	424.20-07	螺丝	SCREW 9/64-40 L=4.5		(2)	
15	424.20-08	扫线开关组件	SOLENOID ASM		1	
16	424.20-08-01	扫线器开关底座	WIPER BASE		(1)	
17	424.20-08-02	扫线器叉口连杆	WIPER LINK		(1)	
18	424.20-08-03	电磁铁	WIPER SOLENOID		(1)	
19	424.20-08-04	橡胶块A	WIPER RUBBER A		(1)	
20	424.20-08-05	橡胶块B	WIPER RUBBER B		(1)	
21	424.20-08-06	扫线器叉口连杆螺套	WIPER HINGE SCREW COLLAR		(1)	
22	424.20-08-07	扭簧	WIPER SPRING		(1)	
23	424.20-08-08	扫线器罩壳	WIPER COVER		(1)	
24	424.20-08-09	扫线器磁铁导向销	WIPER SOLENOID PIN		(1)	
25	424.20-08-10	导向销螺套	WIPER LINK COLLAR		(1)	
26	424.20-08-11	接线头	PIN CONTACT		(2)	
27	424.20-08-12	扫线开关	POWER SWITCH		(1)	
28	424.20-08-13	电线套	2-CORE CABTYRE CORD		(1.5)	
29	424.20-08-14	电线	ELECTRIC WIRE		(0.1)	
30	424.20-08-15	螺帽	NUT 11/64-40		(1)	
31	424.20-08-16	铰链螺钉	HINGE SCREW D=6.5 H=3.2		(1)	
32	424.20-08-17	螺丝	SCREW M3×6		(4)	
33	424.20-08-18	螺丝	SCREW M3×6		(1)	
34	424.20-08-19	弹簧垫圈	SPRING WASHER M3		(4)	
35	424.20-08-20	垫圈	WASHER M3		(1)	
36	424.20-08-21	螺丝	SCREW 11/64-40 L=9.5		(1)	
37	424.20-09	螺丝	SCREW 3/16-28 L=6		2	
38	424.20-10	连杆螺钉	HINGE SCREW D=6 H=2.7		1	
39	424.20-11	连杆螺帽	NUT 11/64-40		1	
40	424.20-12	螺丝	SCREW 11/64-40 L=9		2	
41	424.20-13	垫圈	WASHER		2	

21、专用部件
APPROPRIATION PARTS

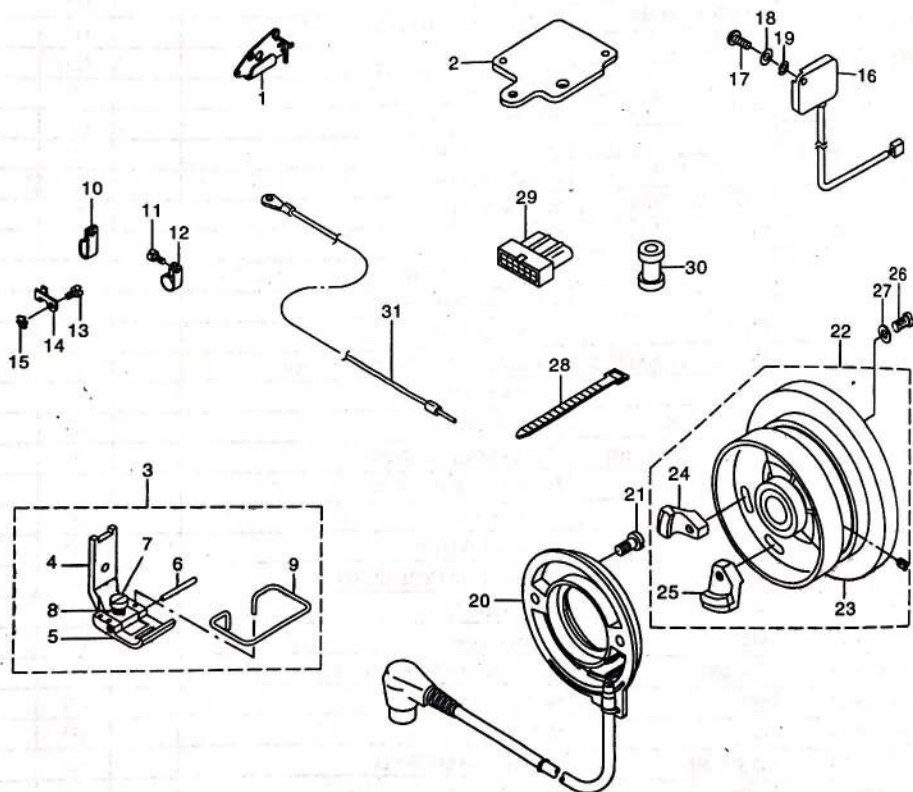

21. 专用部件 APPROPRIATION PARTS

序号	图号	名称	DESCRIPTION	2284	2284-7	备注
1	424.21-01	导线板	BALANCDE THREAD GUIDE		1	
2	424.21-02	螺旋斜齿轮箱盖	HELICAL BEVEL GEAR BOX COVER		1	
3	424.21-03	压脚组件	PRESSER FOOT ASM		1	
4	424.21-03-01	压脚柄	PRESSER UPPER		1	
5	424.21-03-02	压脚底板	PRESSER LOWEROOA		1	
6	424.21-03-03	压脚销	PRESSER PIN A		1	
7	424.21-03-04	螺钉	SCREW 9/64"×40 L=7.5		1	
8	424.21-03-05	压脚弹簧	SPRING		1	
9	424.21-03-06	护指器	SAFETY COVER		1	
10	424.21-04	电线夹	CORD HOLDER LARGE		2	
11	424.21-05	螺钉	SCREW 3/16"×28 L=10		1	
12	424.21-06	电线夹	CABLE CLIP C		1	
13	424.21-07	螺钉	SCREW 3/16"×28 L=10		1	
14	424.21-08	电线夹	CABLE HOLDER		1	
15	424.21-09	齿形垫圈	TOOTHED WASHER D=5.3		1	
16	424.21-10	电阻组件	RESISTANCE DACKAS ASM		1	
17	424.21-11	螺钉	SCREW 3/16"×28 L=14		1	
18	424.21-12	垫片	WASHER 5×10.5×1		1	
19	424.21-13	弹簧垫	SPRING WASHER 5.1×9.2×1.3		1	
20	424.21-14	传感器组件	DYNAMO STATOR		1	
21	424.21-15	螺钉	SCREW		2	
22	424.21-16	上轮组件	HAND WHEEL ASM		1	
23	424.21-16-01	上轮	HAND WHEEL COMPL		1	
24	424.21-16-02	磁铁装置B组件	MAGNET FITTING BASE B ASM		1	
25	424.21-16-03	磁铁装置A组件	MAGNET FITTING BASE A ASM		1	
26	424.21-17	螺钉	SCREW 11/64"×40 L=12		2	
27	424.21-18	垫片	WASHER 4.5×10×0.8		2	
28	424.21-19	轧带	CABLE BAND		2	
29	424.21-20	电线总接头	HOUSING 14P		1	
30	424.21-21	橡皮套	RUBBER PLUG		2	
31	424.21-22	地线组件	GROUND WIRE ASM		1	

22、自动抬压脚装置(可供选择)

AUTO LIFTER (ON THE SIDE PLATE)

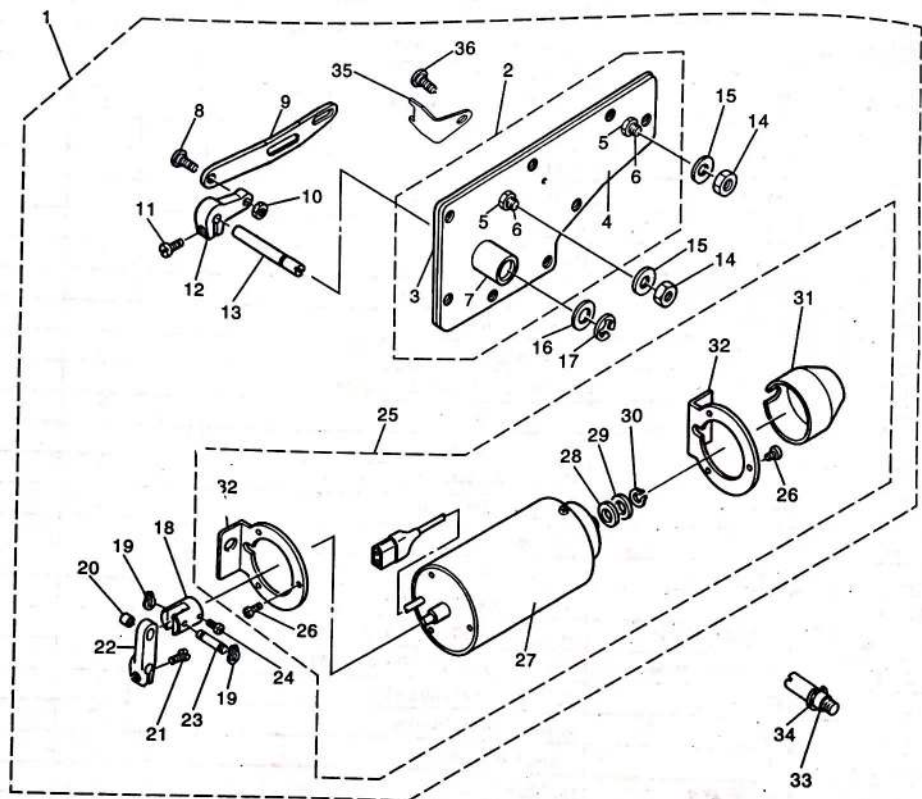

22、自动抬压脚装置 AUTO LIFTER (ON THE SIDE PLATE)

序号	图号	名称	DESCRIPTION	2284	2284-7	备注
1	424.22-01	抬压脚装置组件	DEVICE ASM		(1)	
2	424.22-01-01	后盖板组件A	SIDE PLATE ASM A		(1)	
3	424.22-01-01-01	后盖板	SIDE PLATE		1	
4	424.22-01-01-02	后盖板垫	GASKET		1	
5	424.22-01-01-03	磁铁固定螺母	NUT		2	
6	424.22-01-01-04	磁铁固定螺钉	SCREW		2	
7	424.22-01-01-05	杠杆螺套组件	LEVER SCREW SET ASM		1	
	424.22-01-01-05-01	杠杆螺套	LEVER SCREW SET		1	
	424.22-01-01-05-02	杠杆螺套螺母	LEVER SCREW SET NUT		1	
	424.22-01-01-05-03	密封圈	GASKET		1	
8	424.22-01-02	铰链螺丝	HINGE SCREW D=8 H=3.5		(1)	
9	424.22-01-03	械杆	SOLENOID LINK		(1)	
10	424.22-01-04	螺母	NUT 15/64-28		(1)	
11	424.22-01-05	螺丝	SCREW 3/16-28 L=14		(1)	
12	424.22-01-06	杠杆曲柄	SOLENOID ARM		(1)	
13	424.22-01-07	杠杆轴	SOLENOID SHAFT		(1)	
14	424.22-01-08	螺母	NUT 15/64-28		(2)	
15	424.22-01-09	垫片	WASHER		(2)	
16	424.22-01-10	垫片	WASHER		(1)	
17	424.22-01-11	E型卡簧 7	E-RING 7		(1)	
18	424.22-01-12	轧头	SOLENOID COLLAR		(1)	
19	424.22-01-13	E型卡簧	RING		(2)	
20	424.22-01-14	衬套	SOLENOID PIN COLLAR		(1)	
21	424.22-01-15	螺丝	SCREW 3/16-28 L=12		(1)	
22	424.22-01-16	杠杆曲柄A	SOLENOID ARM A		(1)	
23	424.22-01-17	轧头销	SOLENOID PIN		(1)	
24	424.22-01-18	螺丝	SCREW 11/64-40 L=9		(1)	
25	424.22-01-19	磁铁组件	SOLENOID ASM A		(1)	
26	424.22-01-19-01	螺丝	SCREW 3/16-28 L=9		(6)	
27	424.22-01-19-02	电磁铁组件	WIPER SOLENOID		1	
28	424.22-01-19-03	磁铁橡胶垫	SOLENOID RUBBER A		(1)	
29	424.22-01-19-04	垫片	WASHER 10.5 × 18 × 2		(1)	
30	424.22-01-19-05	止动环	RETAINING RING		(1)	
31	424.22-01-19-06	磁铁罩	SOLENOID COVER		(1)	
32	424.22-01-19-07	电磁铁支承板	SOLENOID BASE		(2)	
33	424.22-01-20	轴销组件	SHAFT PIN ASM		1	
34	424.22-01-21	E型卡簧 5	E-RING		(1)	
35	424.22-01-22	限位板	PLATE OF POSITION		1	
36	424.22-01-23	限位板螺钉	SCREW		(1)	

说明：无自动抬压脚装置时仍然用423.01-18、423.01-19零件，并在附件中增加423.14-05操纵板组件一套。

23、附件部件

ACCESSORIES COMPONENTS

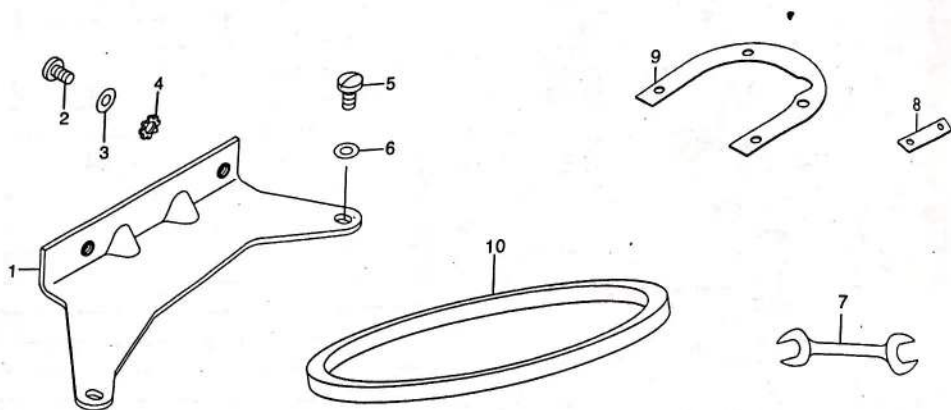

23、附件部件ACCESSORIES COMPONENTS

序号	图号	名称	DESCRIPTION	2284	2284-7	备注
1	424.23-01	支架	BRACKET		1	
2	424.23-02	螺钉	SCREW 11/64-40 L=7.8		2	
3	424.23-03	垫片	WASHER 4.5 × 10 × 0.8		2	
4	424.23-04	齿形垫圈	TOOTHED WASHER D=5.3		2	
5	424.23-05	螺钉	SCREW 3/16-28 L=9		2	
6	424.23-06	垫片	WASHER		2	
7	424.23-07	5-6扳手	WASHER		2	
8	424.23-08	牙齿垫片	SPACER		1	
9	424.23-09	针板垫片	SPACER		1	
10	424.23-10	皮带	BELT		1	
					1	